



Version 2.0 / Updated 2/9/07

The RREEF Corporate Identity Property Management Sign Program



Section A:

The RREEF Corporate Logo, Colors & Typefaces



Section A Table of Contents

Sections:

A The RREEF Corporate Logo, Colors & Typefaces

B Property Management Marketing Signs

C Property Management Marketing Materials

D Office Building Signs

E On-Site Management / Leasing Office Signs

The RREEF Corporate Logo, Colors & Typefaces

Page: Description:

A1.1 The RREEF Logo - Approved Usage

A1.2 The RREEF Logo - Logo Colors

A1.3 The RREEF Logo - Logo Color Matching

A1.4 The RREEF Typefaces



The RREEF Logo - Approved Usage

Approved Usage.

The RREEF corporate logo has been carefully designed to reflect the professionalism of our organization. The RREEF logo is:



Some rules of the usage of the RREEF logo are as follows:

- The box around the "RR's" and the RREEF letters defines the shape of the logo and must always be used. The "RR's" and RREEF letters should never be reversed out or used alone.
- The "RR's", should never be used without the RREEF letters below.
- Conversely, the RREEF letters should also never be used without the "RR's" above.
- The RREEF logo should never appear as:



OR



OR





The RREEF Logo - Logo Colors

Logo Colors.

The required color for the RREEF logo is PMS 287*, which is a shade of blue. PMS refers to the Pantone Matching System, a color standard that is familiar to any printer, designer or sign maker. In some cases, black or white may be used as alternatives as indicated below.

Blue or black should be used for the box, with the "RR's" and RREEF letters reversed in the background color, which is preferred to be white. These would appear as:



OR



White may be used when rendering the logo on any dark background, or when placed upon glass windows or doors. These would appear as:



PMS 430 Background

OR



Glass Background

Color Combinations NOT Approved.

The following color combinations and arrangements are not allowed (unless indicated in specific applications in this manual):



(The RREEF logo in any color other than PMS 287, black or white.)



(The RREEF logo in any color other than white on a dark background or glass.)



(The blue or black logo on any background color other than white.)



(The RR's or RREEF letters reversed in any color other than the background color.)

*Caution - do not use the printed colors rendered as PMS 287 or PMS 430 in this book as samples to match. The printing of this material may not have occurred in controlled circumstances.



The RREEF Logo - Logo Color Matching

Color Matching.

Below are some product colors that match the RREEF logo colors. Please note that in some cases the products may need to be further custom mixed to achieve the correct color.

Products:	RREEF Blue	RREEF Grey	RREEF White	RREEF Black
PMS	287*	430*	N/A	Process Black
Sign Enamel	#155 1-Shot Reflex Blue**	#195 1-Shot Medium Grey**	#101 1-Shot White	#199 1-Shot Black
Premium Vinyl	#220-37 3M Sapphire Blue	N/A	#220-10 3M White	#220-12 3M Black
Stain	N/A	N/A	N/A	Sherwin Williams Woodscapes Solid Wood Stain

*Caution - do not use the printed colors rendered as PMS 287 or PMS 430 in this book as samples to match. The printing of this material may not have occurred in controlled circumstances.

**Some mixing may be required to match the RREEF color.



RREEF Typefaces.

Below are the typefaces approved for use on RREEF signs, except where specifically noted in the Sign Program in rare instances. Only the matching typeface may be used on the particular sign shown and no substitutions are allowed.

Arial

ABCDEFGHIJKLMNOPQRSTUVWXYZabcdefghijklmnopqrstuvwxyz1234567890()

Arial Bold

ABCDEFGHIJKLMNOPQRSTUVWXYZabcdefghijklmnopqrstuvwxyz1234567890()



Section B:

Property Management Marketing Signs



Section B Table of Contents

Sections:

- A** **The RREEF Corporate Logo, Colors & Typefaces**
- B** **Property Management Marketing Signs**
- C** **Property Management Marketing Materials**
- D** **Office Building Signs**
- E** **On-Site Management / Leasing Office Signs**

Property Management Marketing Signs

Page:	Description:
B1.1	RREEF Standard 4' x 6' "For Lease" Sign
B1.2	RREEF Standard 2' x 3' "For Lease" Sign
B1.3	Standard "For Lease" Sign Rider Options & Photo
B1.4	Standard "For Lease" Sign Configurations & V-Shape Photo
B2.1	RREEF Upright "For Lease" Sign
B2.2	Upright "For Lease" Sign Detail & Photo
B3.1	RREEF Upgraded 10' x 8' "For Lease" Sign
B3.2	RREEF Upgraded 7' x 5'-6" "For Lease" Sign
B3.3	Upgraded "For Lease" Sign Section Detail & Photo
B4.1	RREEF "Managed By" Sign
B4.2	"Managed By" Sign Photo
B5.1	Site Plan Exhibit A
B5.2	"Managed By" Sign Placement Details
B5.3	"For Lease" Sign & Office Directional Sign Placement Details
B5.4	Typical Ground Installation Details
B5.5	Typical Panel Attachment Details



RREEF Standard 4' x 6' "For Lease" Sign

General Requirements:

This sign is used primarily at industrial and suburban office properties.

Signs should be placed along property street frontage and should be used for all marketing efforts even when listed with brokers. For typical placement, see Site Plan Exhibit A on page B5.1.

Signs may be double-faced, single-faced or v-shaped (see page B1.4).

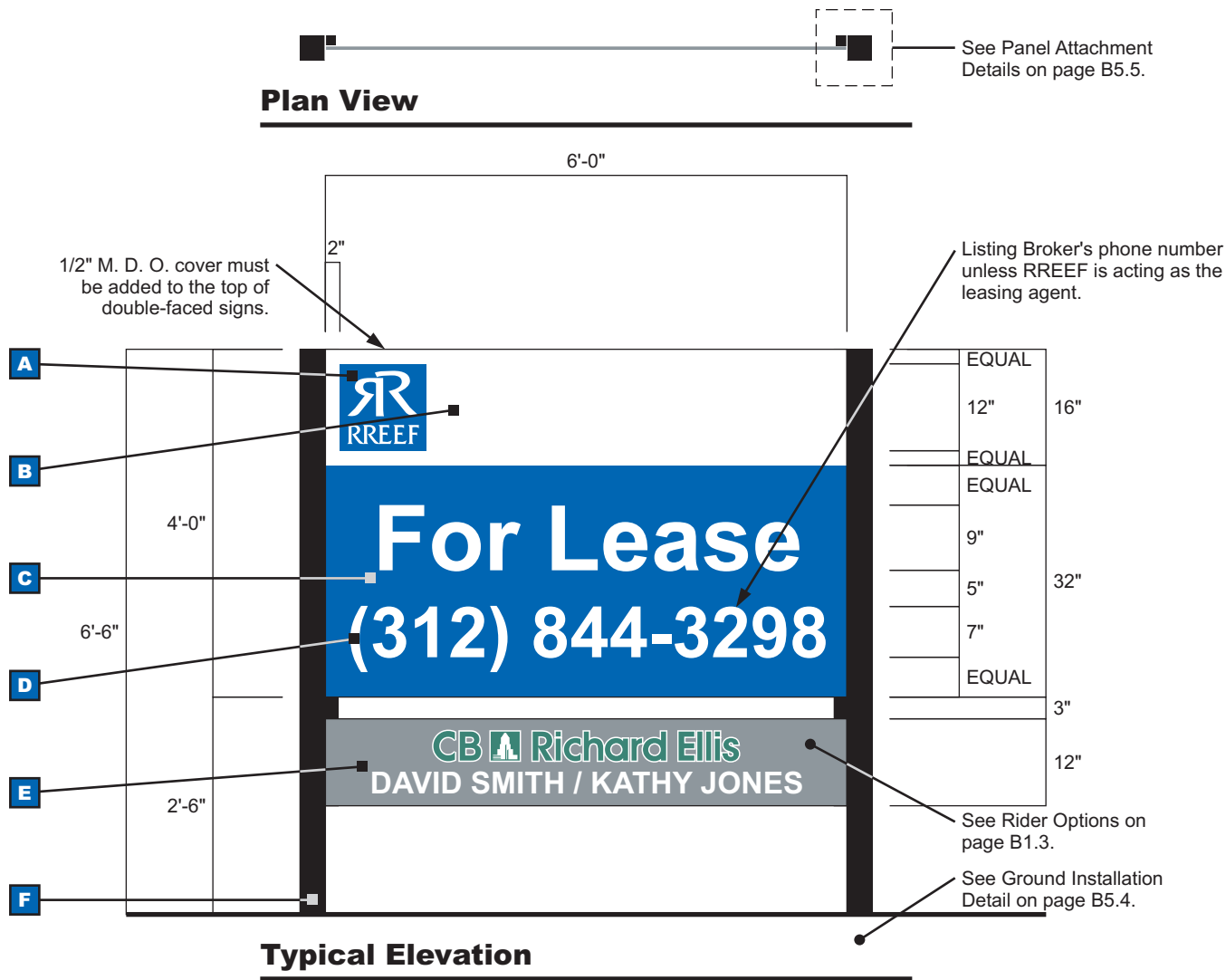

Specifications:

- A** #220-37 Sapphire Blue 3M Scotchcal Premium Vinyl Film.
- B** 3/4" Single-Sided M. D. O. Panel* with #101 White 1-Shot Graphic Coat Bulletin Enamel finish.
- C** Background area painted with 1-Shot Graphic Coat Bulletin Enamel finish to match PMS 287C.**
- D** #220-10 White 3M Scotchcal Premium Vinyl Film. Font must be Arial Bold.
- E** 3/4" Single-Sided M. D. O. Panel* with 1-Shot Graphic Coat Bulletin Enamel finish to match PMS 430C.***
- F** 4" x 4" Grade 2 or Better Douglas Fir Posts stained with Black Sherwin Williams Woodscapes Solid Stain.****

*All M. D. O. panels are to be sealed and primed on front surface and edges with 1-Shot 5005 Acrylic Bonding Primer prior to finish coat. Face color is to be returned around adjacent edges. Rear surfaces of single-sided or v-shaped signs are to be stained with Black Sherwin Williams Woodscapes Solid Stain. Double-face signs should incorporate 2 single-sided panels back to back (see B1.4).

**Corresponding color is #155 1-Shot Reflex Blue.

***Corresponding color is #195 1-Shot Medium Grey.

****All posts must be stained completely on all surfaces before below ground installation.



RREEF Standard 2' x 3' "For Lease" Sign

General Requirements:

This sign is used primarily at industrial and suburban office properties.

Signs should be placed along property street frontage and should be used for all marketing efforts even when listed with brokers. For typical placement, see Site Plan Exhibit A on page B5.1.

Signs may be double-faced, single-faced or v-shaped (see page B1.4).

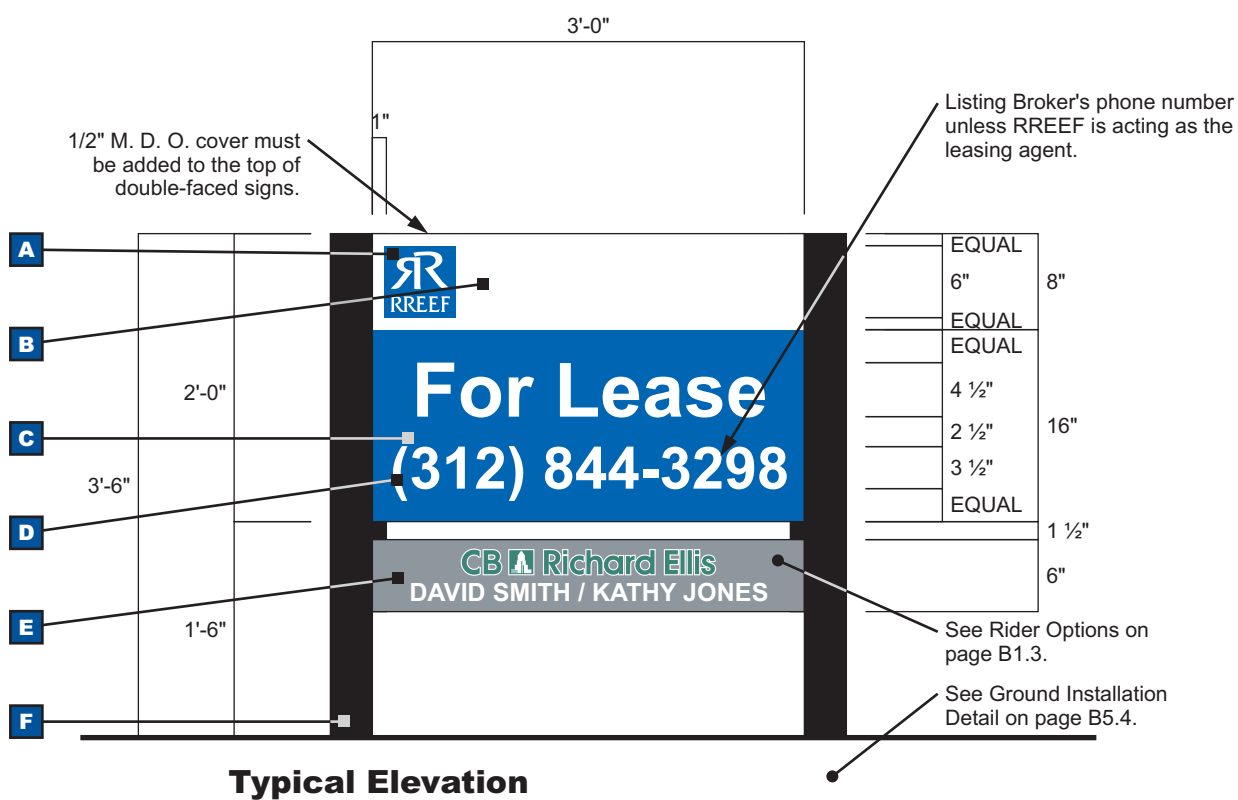

Specifications:

- A** #220-37 Sapphire Blue 3M Scotchcal Premium Vinyl Film.
- B** 3/4" Single-Sided M. D. O. Panel* with #101 White 1-Shot Graphic Coat Bulletin Enamel finish.
- C** Background area painted with 1-Shot Graphic Coat Bulletin Enamel finish to match PMS 287C.**
- D** #220-10 White 3M Scotchcal Premium Vinyl Film. Font must be Arial Bold.
- E** 3/4" Single-Sided M. D. O. Panel* with 1-Shot Graphic Coat Bulletin Enamel finish to match PMS 430C.***
- F** 4" x 4" Grade 2 or Better Douglas Fir Posts stained with Black Sherwin Williams Woodscapes Solid Stain.****

*All M. D. O. panels are to be sealed and primed on front surface and edges with 1-Shot 5005 Acrylic Bonding Primer prior to finish coat. Face color is to be returned around adjacent edges. Rear surfaces of single-sided or v-shaped signs are to be stained with Black Sherwin Williams Woodscapes Solid Stain. Double-face signs should incorporate 2 single-sided panels back to back (see B1.4).

**Corresponding color is #155 1-Shot Reflex Blue.

***Corresponding color is #195 1-Shot Medium Grey.

****All posts must be stained completely on all surfaces before below ground installation.



Standard "For Lease" Sign Rider Options & Photo

Rider Options:

Rider may depict special marketing efforts, broker names, size of spaces, broker logos and specific notes, i. e. "Do Not Disturb Tenants."

All copy including broker names, size of spaces, notes and special messages must be in Arial Bold style letters in #220-10 white 3M Scotchcal Premium Vinyl Film.

Broker logos can be in broker colors with a #220-10 white 3M Scotchcal Premium Vinyl Film outline.

A maximum of two riders may be used.



Broker logo may be in broker's colors with a #220-10 White outline.

All other copy must be in #220-10 White.

Typical "Over and Under" Rider Alternative

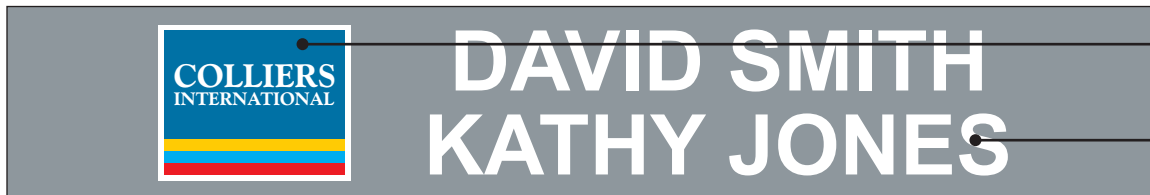

Broker logo may be in broker's colors with a #220-10 White outline.

All other copy must be in #220-10 White.

Typical "Side by Side" Rider Alternative



Standard "For Lease" Sign Rider Photo

Possible Configurations:

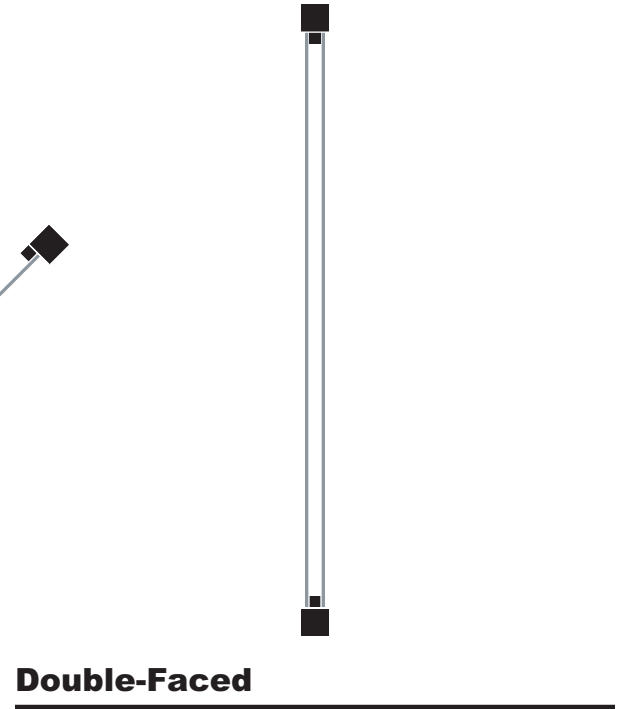
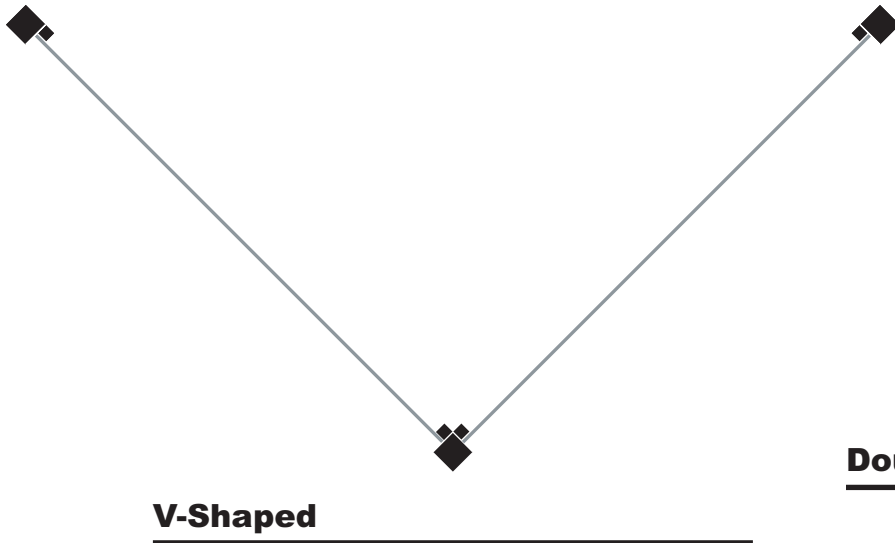

Photo to be added later.



RREEF Upright "For Lease" Sign

General Requirements:

This sign is used primarily at industrial and suburban office properties. It is of higher cost than the Standard sign, but lends an upper-scale image to the property upon which it is placed.

Signs should be placed along property street frontage and should be used for all marketing efforts even when listed with brokers. For typical placement, see Site Plan Exhibit A on page B5.1.

Signs may be double or single faced. If single, back surface should be painted black.

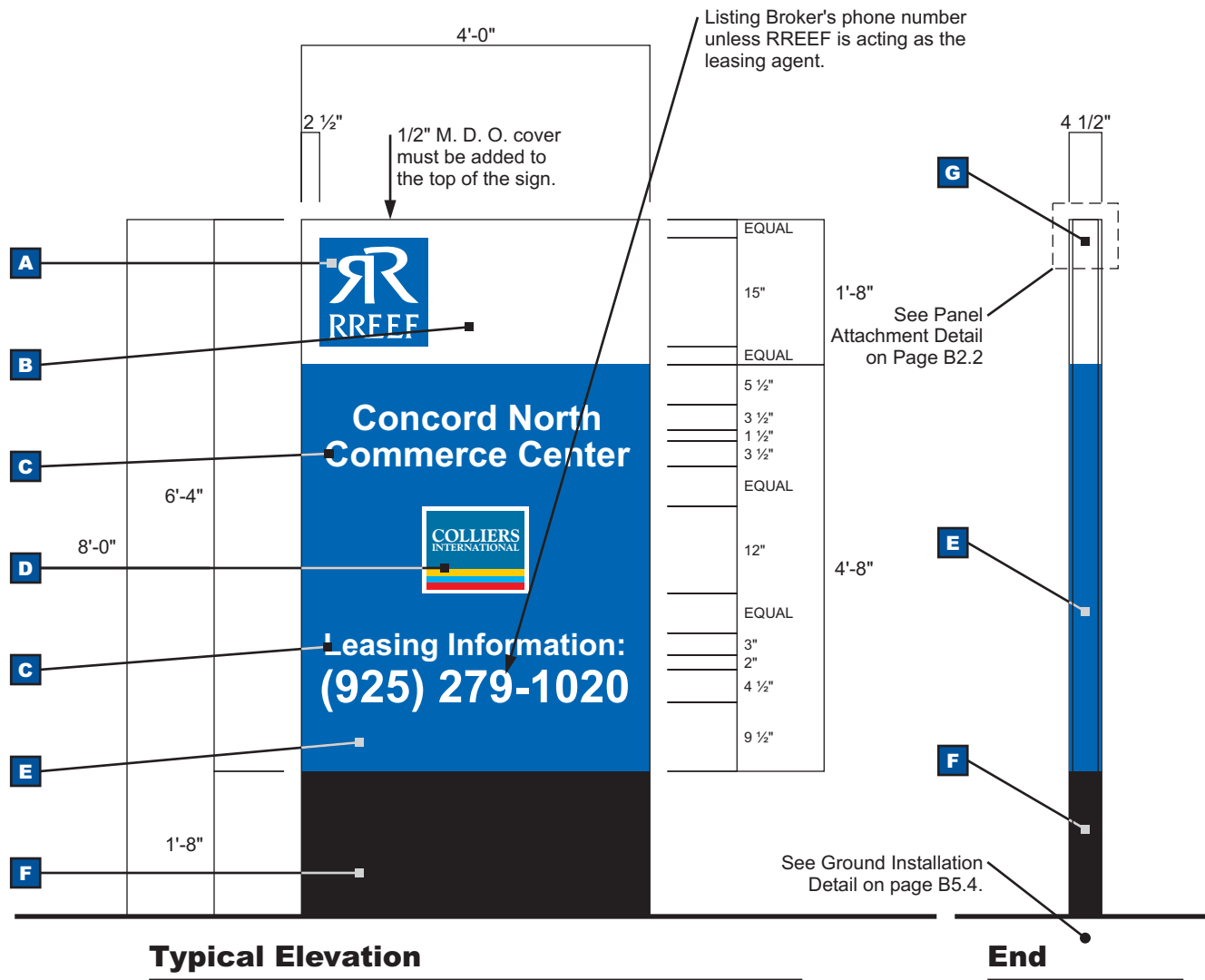

Specifications:

- A** #220-37 Sapphire Blue 3M Scotchcal Premium Vinyl Film.
- B** 1/2" Single-Sided M. D. O. Panel* with #101 White 1-Shot Graphic Coat Bulletin Enamel finish.
- C** #220-10 White 3M Scotchcal Premium Vinyl Film. Font must be Arial Bold.
- D** Broker logo in broker's colors as desired.
- E** Background area painted with 1-Shot Graphic Coat Bulletin Enamel finish to match PMS 287C.**
- F** Background area painted with #199 Black 1-Shot Graphic Coat Bulletin Enamel finish.
- G** 4" x 4" Grade 2 or better Douglas Fir posts painted on all surfaces with 1-Shot 5005 Acrylic Bonding Primer and 1-Shot Graphic Coat Bulletin Enamel before below ground installation.

*All M. D. O. panels are to be sealed and primed on front surface and edges with 1-Shot 5005 Acrylic Bonding Primer prior to finish coat. Face color is to be returned around adjacent edges. Rear surfaces of single-sided signs are to be stained with Black Sherwin Williams Woodscapes Solid Stain.

**Corresponding color is #155 1-Shot Reflex Blue.

B2.1

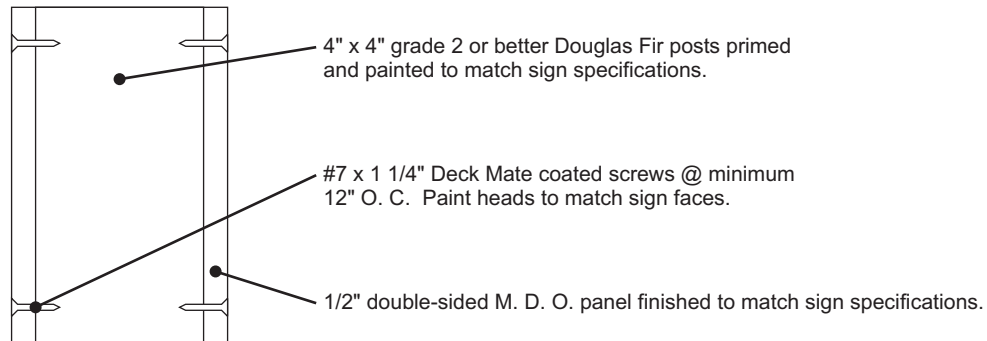

Upright "For Lease" Sign Panel Attachment Detail



Upright "For Lease" Sign Photo



RREEF Upgraded 10' x 8' "For Lease" Sign

General Requirements:

This sign is used at suburban office properties. It is of higher cost than the Standard and Upright sign, but gives the highest scale image to the property upon which it is placed.

Signs should be placed along property street frontage and should be used for all marketing efforts even when listed with brokers. For typical placement, see Site Plan Exhibit A on page B5.1.

Signs should always be double faced.

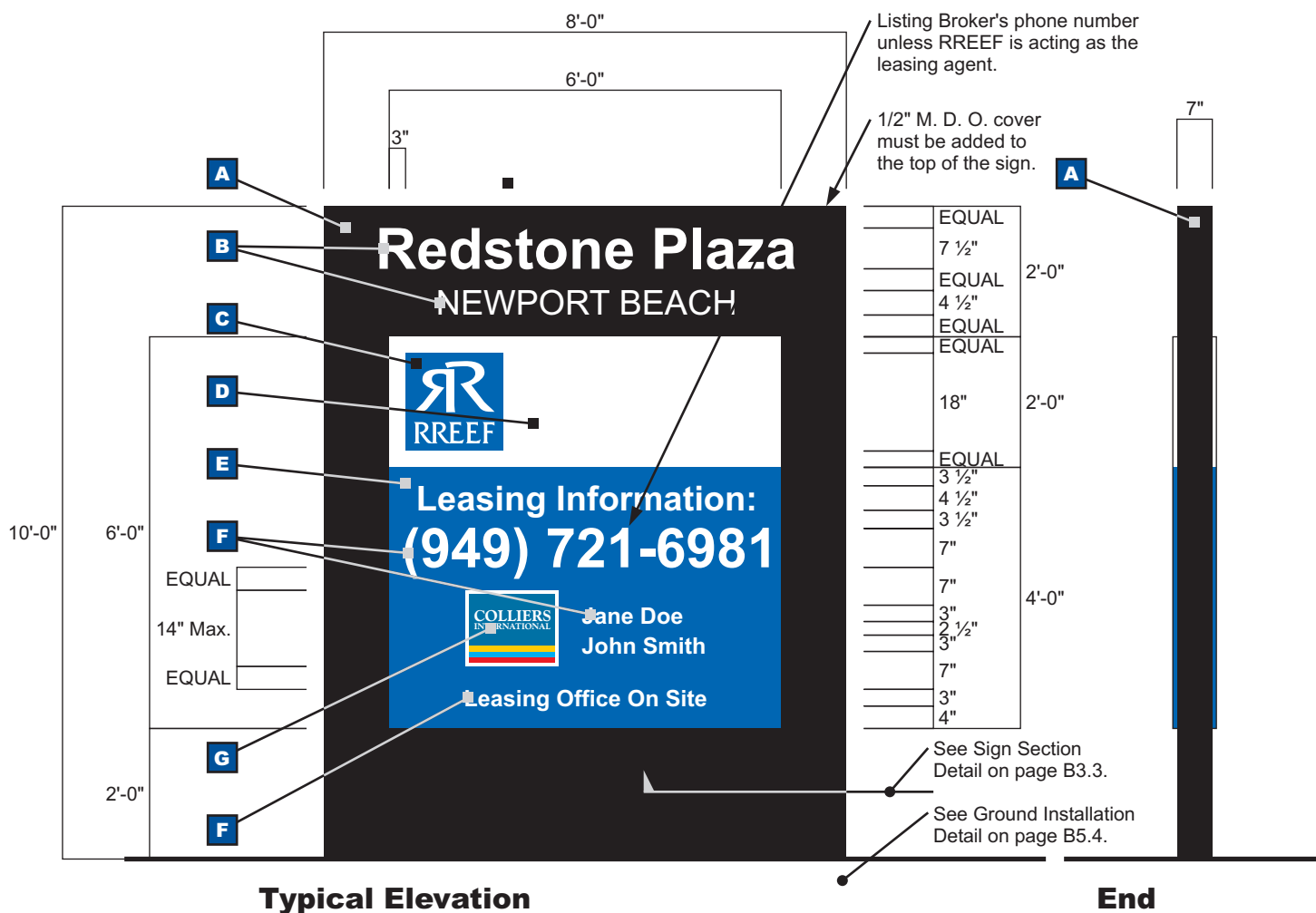

Specifications:

- A** 3/4" Single-Sided M. D. O. facing* with #199 Black 1-Shot Graphic Coat Bulletin Enamel finish.
- B** 1/2" thick #7508 White Gemini Laser-cut Acrylic letters.** Font must be Arial Bold.
- C** #220-37 Sapphire Blue 3M Scotchcal Premium Vinyl Film.
- D** 3/4" Single-Sided M. D. O. Panel* with #101 White 1-Shot Graphic Coat Bulletin Enamel finish.
- E** Background area painted with 1-Shot Graphic Coat Bulletin Enamel finish to match PMS 287C.***
- F** #220-10 White 3M Scotchcal Premium Vinyl Film. Font must be Arial Bold.
- G** Broker logo in broker's colors as desired.

*All M. D. O. panels are to be sealed and primed on front surface, rear surface and edges with 1-Shot 5005 Acrylic Bonding Primer prior to finish coat. Facing panel edges are to have 45° miter corners to eliminate seams.

**All plastic letters and scores to be permanently secured to facing by V. H. B. tape and silicone adhesive.

***Corresponding color is #155 1-Shot Reflex Blue.

B3.1



RREEF Upgraded 7' x 5'-6" "For Lease" Sign

General Requirements:

This sign is used at suburban office properties. It is of higher cost than the Standard and Upright sign, but gives the highest scale image to the property upon which it is placed.

Signs should be placed along property street frontage and should be used for all marketing efforts even when listed with brokers. For typical placement, see Site Plan Exhibit A on page B5.1.

Signs should always be double faced.

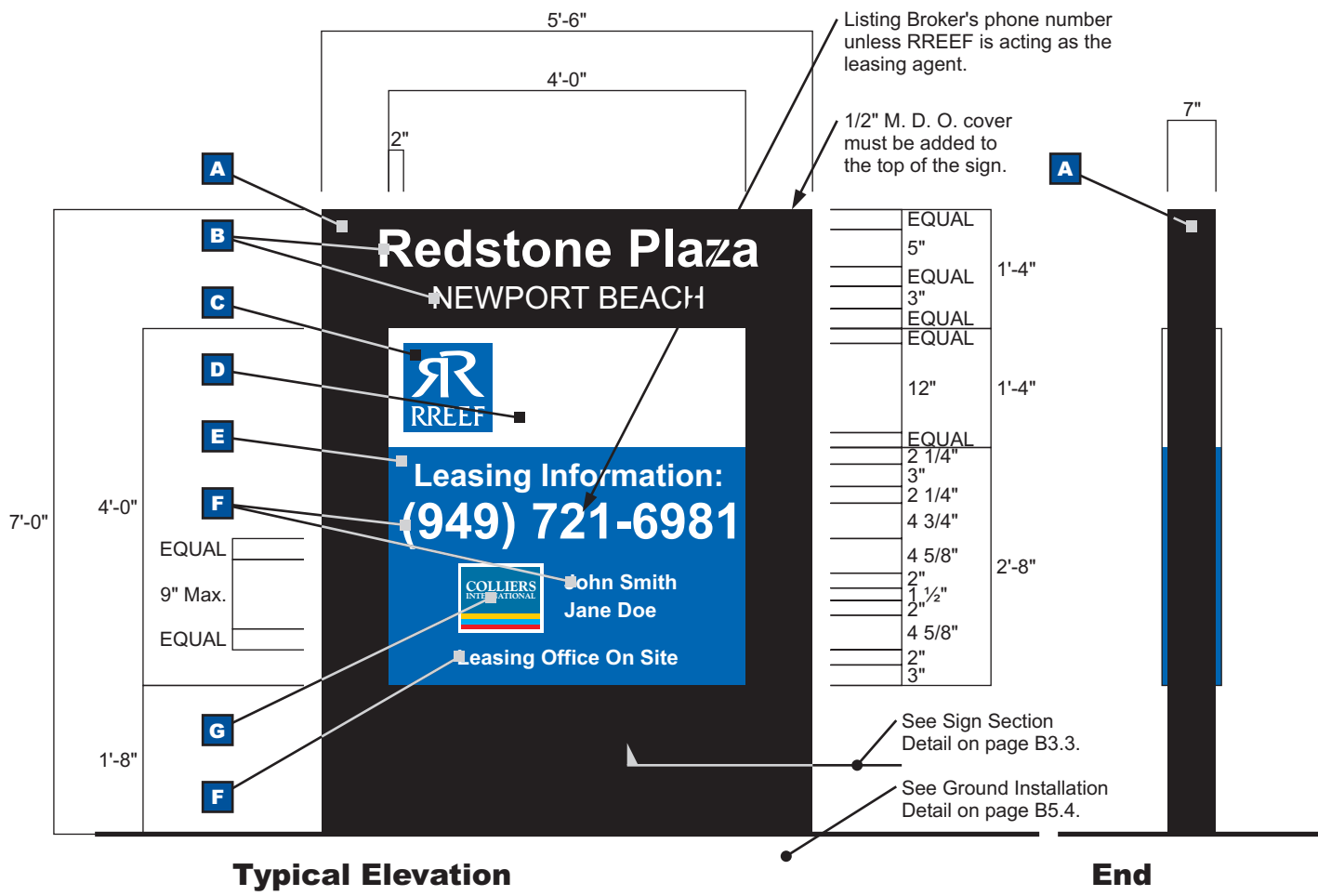

Specifications:

- A** 3/4" Single-Sided M. D. O. facing* with #199 Black 1-Shot Graphic Coat Bulletin Enamel finish.
- B** 1/2" thick #7508 White Gemini Laser-cut Acrylic letters.** Font must be Arial Bold.
- C** #220-37 Sapphire Blue 3M Scotchcal Premium Vinyl Film.
- D** 3/4" Single-Sided M. D. O. Panel* with #101 White 1-Shot Graphic Coat Bulletin Enamel finish.
- E** Background area painted with 1-Shot Graphic Coat Bulletin Enamel finish to match PMS 287C.***
- F** #220-10 White 3M Scotchcal Premium Vinyl Film. Font must be Arial Bold.
- G** Broker logo in broker's colors as desired.

*All M. D. O. panels are to be sealed and primed on front surface, rear surface and edges with 1-Shot 5005 Acrylic Bonding Primer prior to finish coat. Facing panel edges are to have 45° miter corners to eliminate seams.

**All plastic letters and scores to be permanently secured to facing by V. H. B. tape and silicone adhesive.

***Corresponding color is #155 1-Shot Reflex Blue.

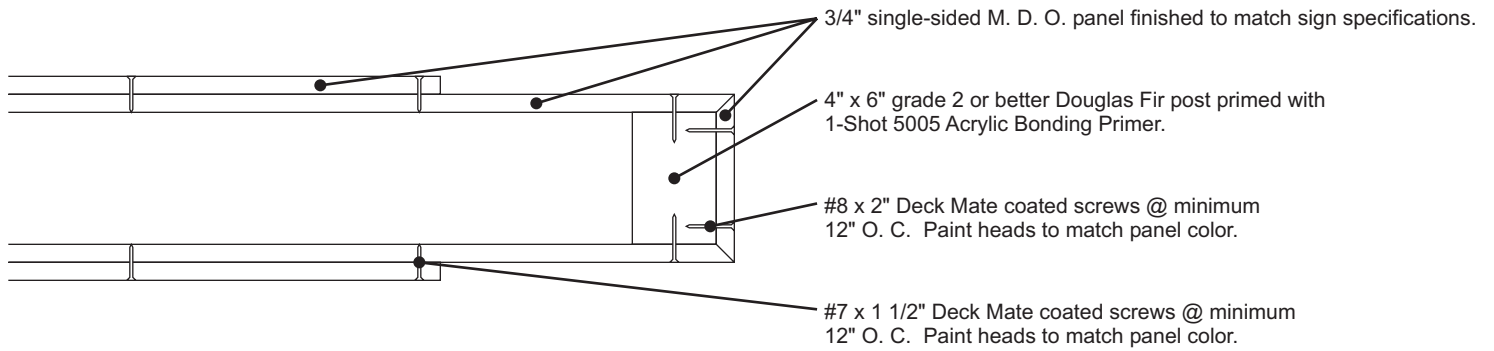

Upgraded "For Lease" Sign Section Detail

Photo to be added later.

Upgraded "For Lease" Sign Section Photograph

General Requirements:

This sign is to be used on all RREEF managed properties to identify who manages the property and not to market RREEF.

Signs should be subtly placed within the complex and not on the main street frontages.

For typical placement, see Site Plan Exhibit A on page B5.1.

Signs may be double-faced or single-faced (see page B1.4).

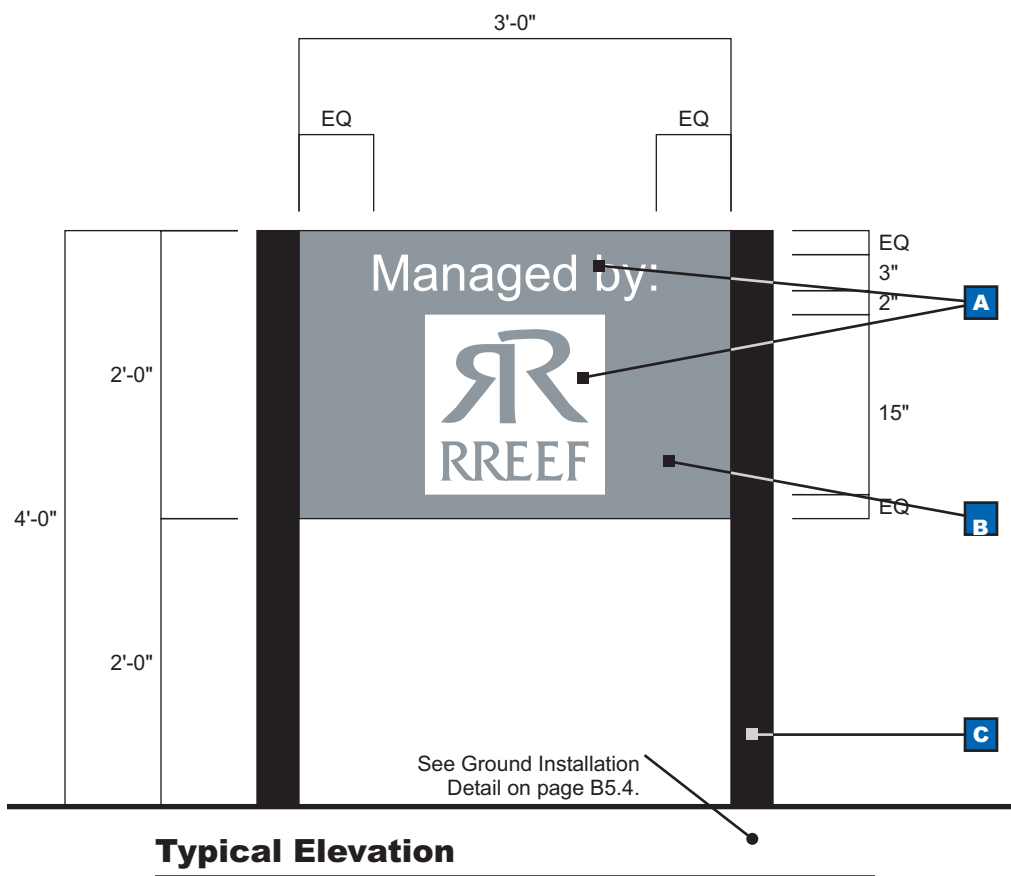
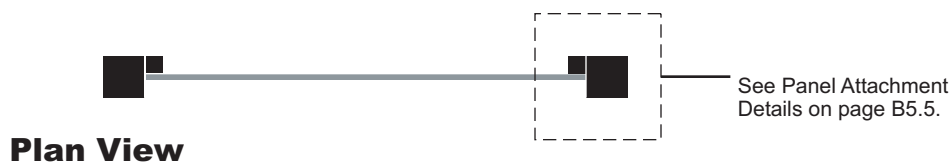

Specifications:

- A** #220-10 White 3M Scotchcal Premium Vinyl Film.
- B** 3/4" Single-Sided M. D. O. Panel* with 1-Shot Graphic Coat Bulletin Enamel finish to match PMS 430C.**
- C** 4" x 4" Grade 2 or Better Douglas Fir Posts stained with Black Sherwin Williams Woodscapes Solid Stain.***

*All M. D. O. panels are to be sealed and primed on front surface and edges with 1-Shot 5005 Acrylic Bonding Primer prior to finish coat. Face color is to be returned around adjacent edges. Rear surfaces are to be stained with Black Sherwin Williams Woodscapes Solid Stain.

**Corresponding color is #195 1-Shot Medium Grey.

***All posts must be stained completely on all surfaces before below ground installation.



Typical "Managed By" Sign Photo

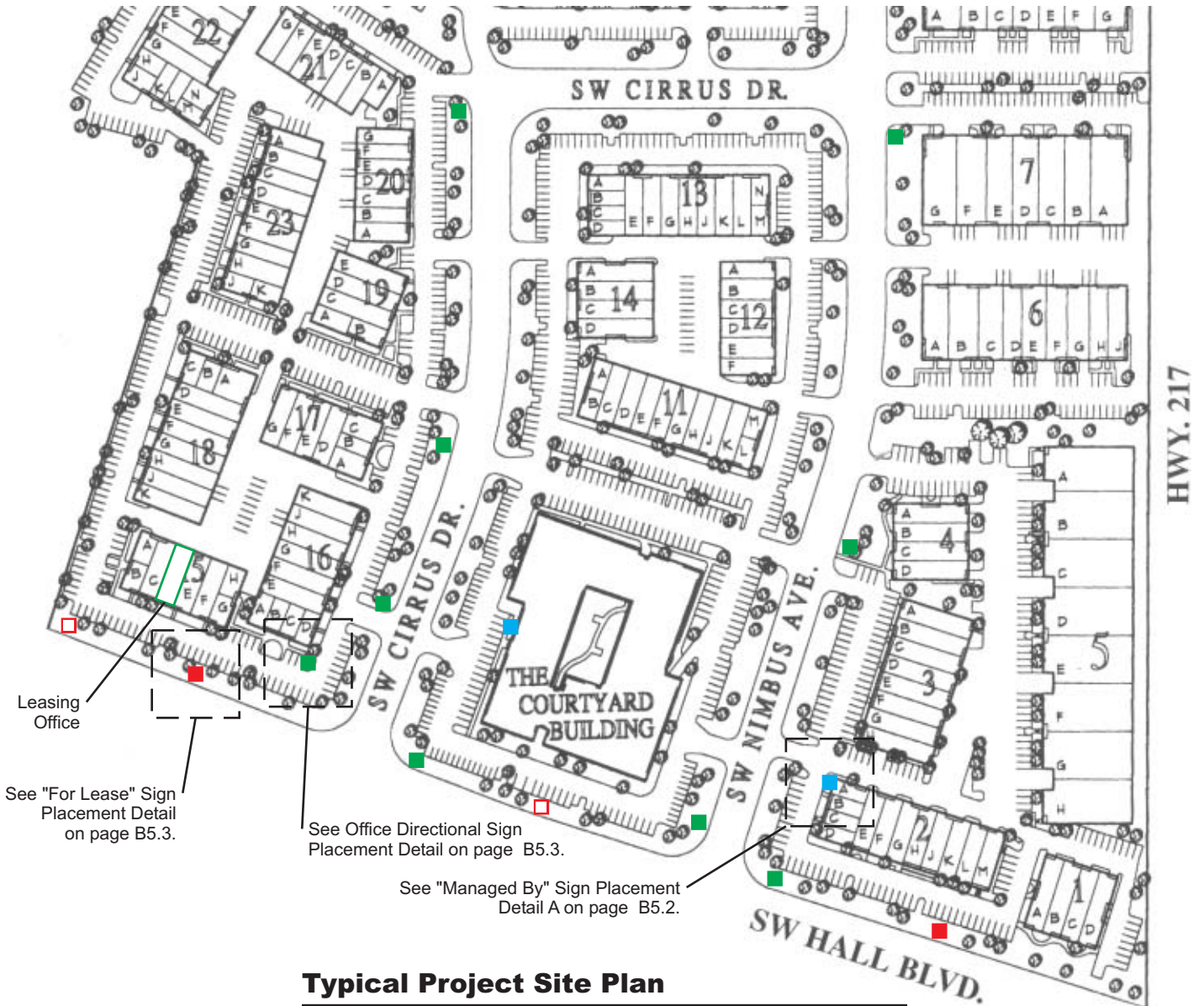

Typical Project Site Plan

Key

- "For Lease" Sign Mandatory Locations*
- "For Lease" Sign Additional Locations**
- "Managed By" Sign Typical Locations***
- Office Directional Sign Typical Locations

*One "For Lease" Sign is required at each end of the property along its frontage on every major street or highway, if the frontage exceeds 150 feet. Only one sign is required if the frontage is 150 feet or less.

**Up to two additional "For Lease" Signs can be added in any combination and located according to the Property Manager's discretion. The locations shown are suggestions only.

***One "Managed By" Sign may be placed on each interior street away from the major street frontage. See "Managed By" Placement Detail B on page B5.2 for typical placement on properties without interior streets.

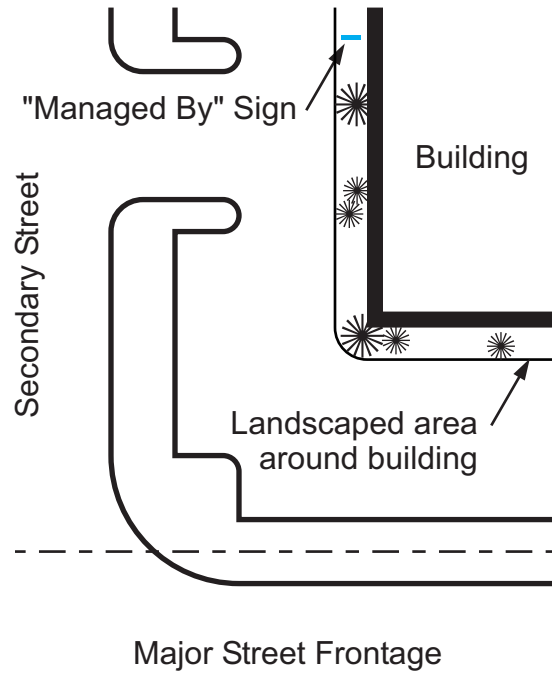

"Managed By" Sign Placement Detail A

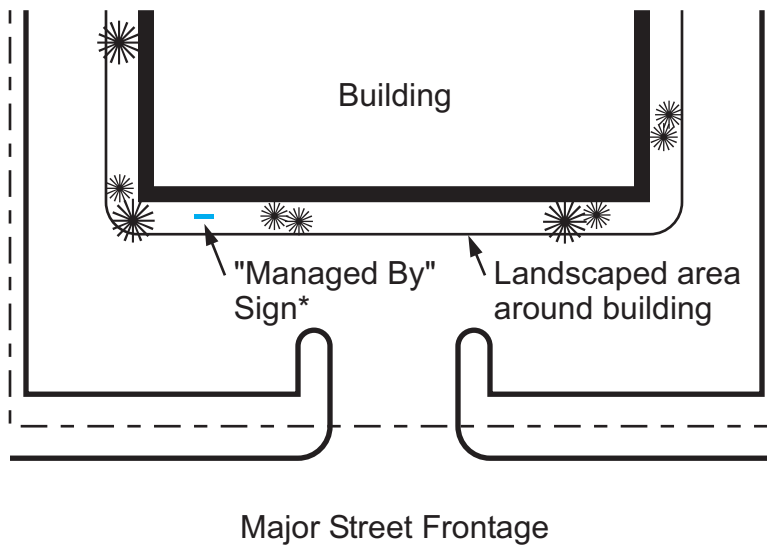

"Managed By" Sign Placement Detail B

*This is only allowable where no Secondary Street Frontage exists.

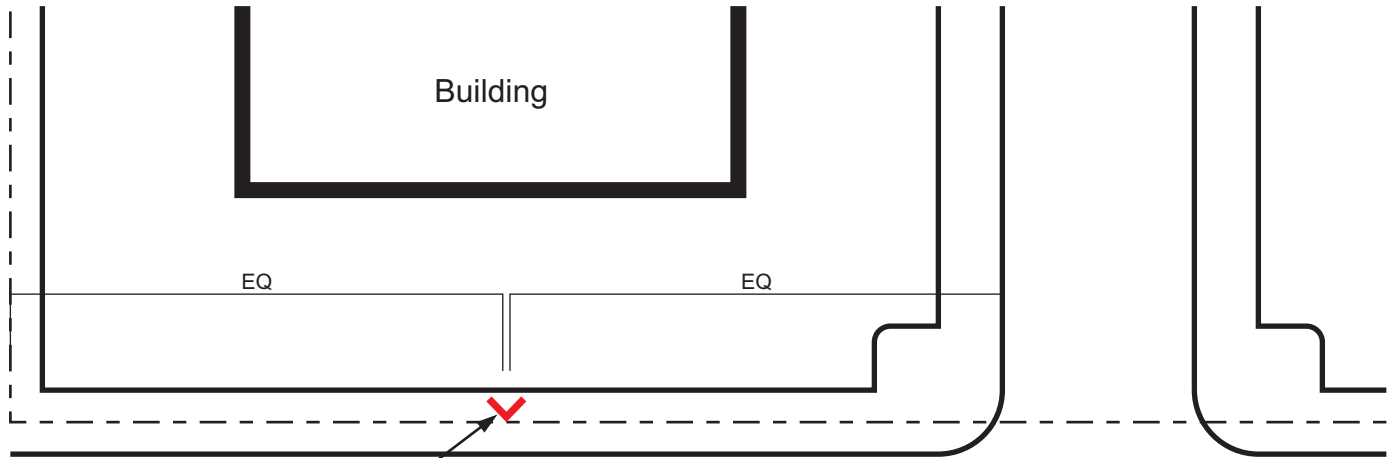

All "For Lease" Sign types placed no closer than the property line to the street

Major Street Frontage

Typical "For Lease" Sign Placement Detail

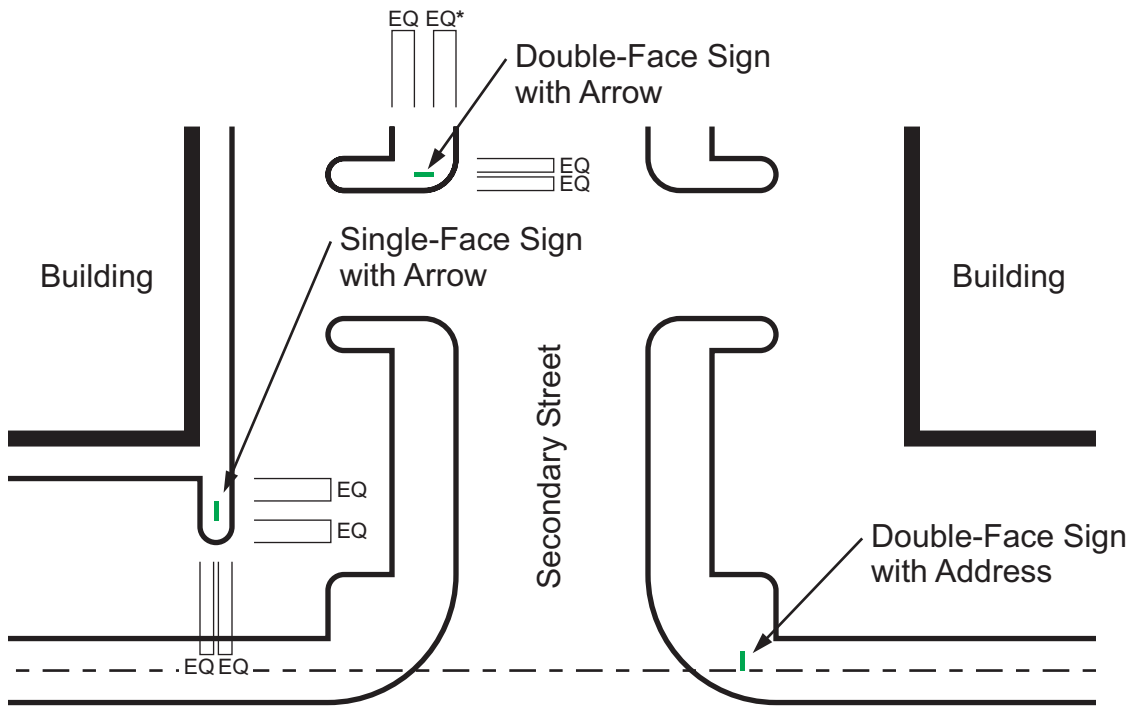

Major Street Frontage

Typical Office Directional Sign Placement Detail

*Sign may be placed at 10' from the curb or equidistant from the curb to the parking area, whichever distance is least.

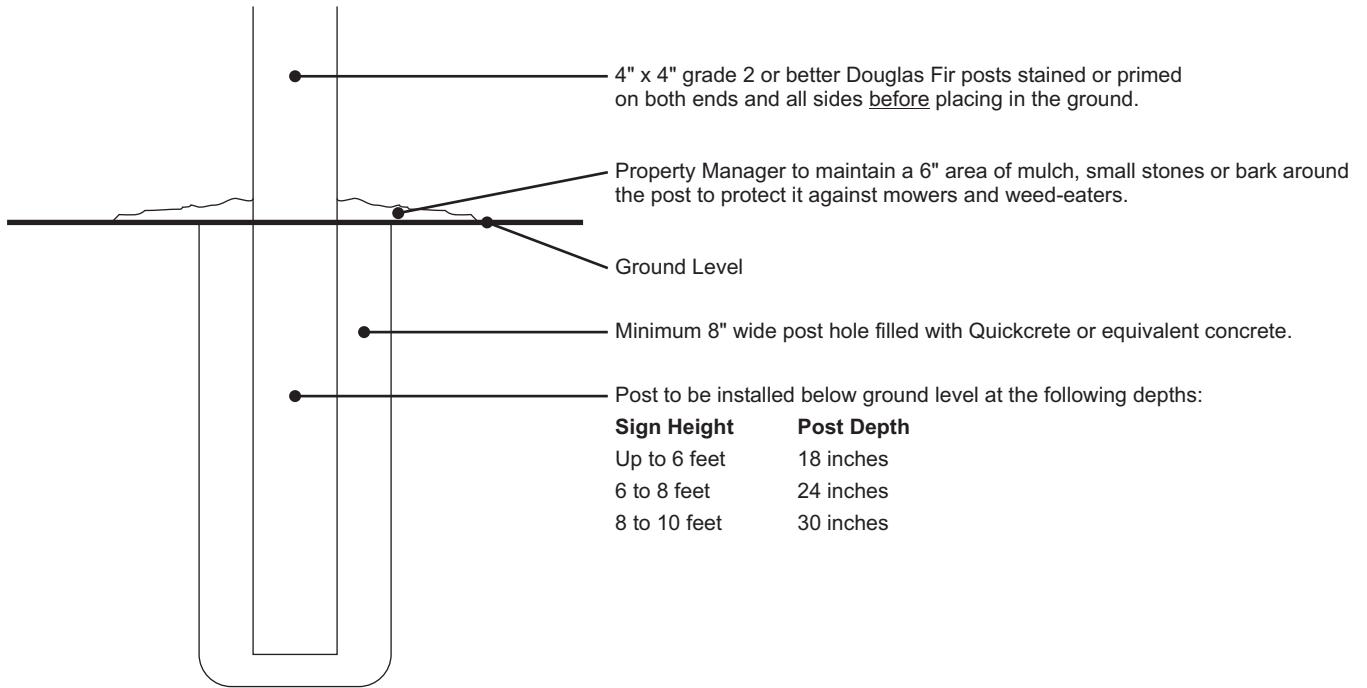

Ground Installation Detail (all Sign Types Except Upgraded "For Lease" Sign)

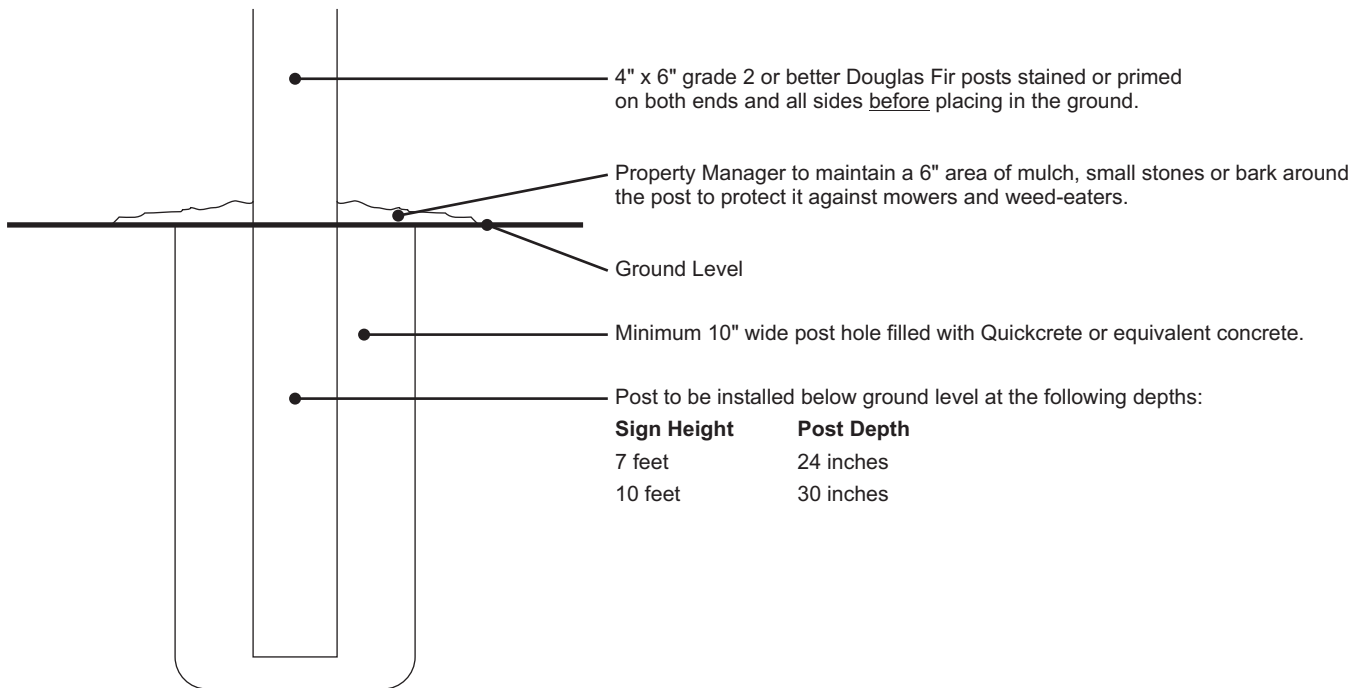

Upgraded "For Lease" Sign Ground Installation Detail

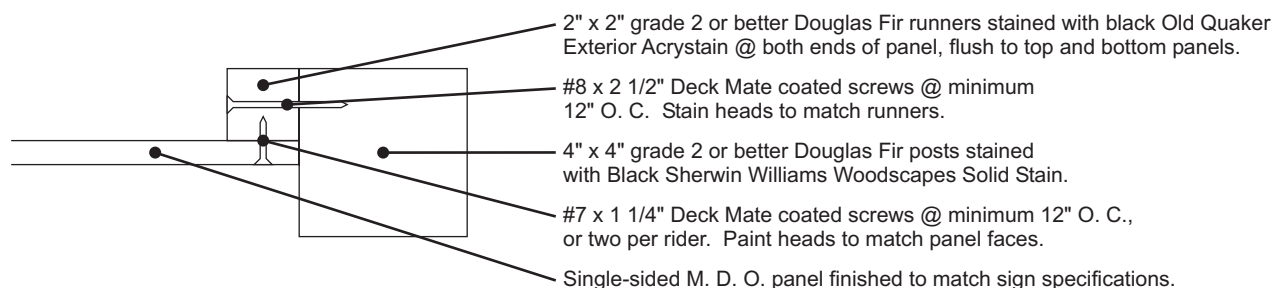

Panel Attachment Detail Single-Faced or V-Shaped Version

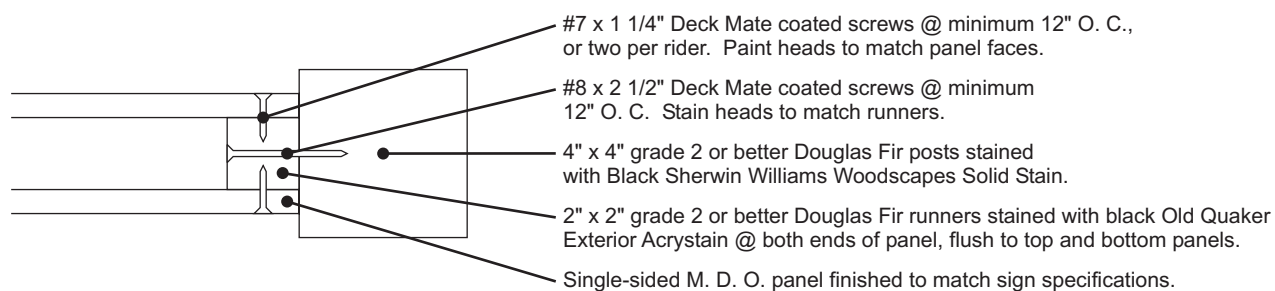

Panel Attachment Detail Double-Faced Version



Section C:

Property Management Marketing Materials



Section C Table of Contents

Sections:

- A** The RREEF Corporate Logo, Colors & Typefaces
- B** Property Management Marketing Signs
- C** Property Management Marketing Materials
- D** Office Building Signs
- E** On-Site Management / Leasing Office Signs

Property Management Marketing Materials

Page:	Description:
C1.1	RREEF Marketing Display Board
C1.2	RREEF Marketing Display Board Photo
C2.1	RREEF Entrance Mats
C2.2	RREEF Entrance Mat Photo
C3.1	RREEF Leasing Banners
C3.2	RREEF Leasing Banner Photo
C3.3	RREEF Leasing Banner Sections & Details
C4.1	Electrical Notice Signs
C4.2	Electrical Notice Sign Photo
C5.1	4' x 6' Flag
C6.1	5' x 8' Flag



RREEF Marketing Display Board

General Requirements:

These are to be located inside the entrance door to all vacant units.

You may include a property brochure, a site plan, a suite floor plan and rental applications, etc. National Leasing flyers should not be displayed.

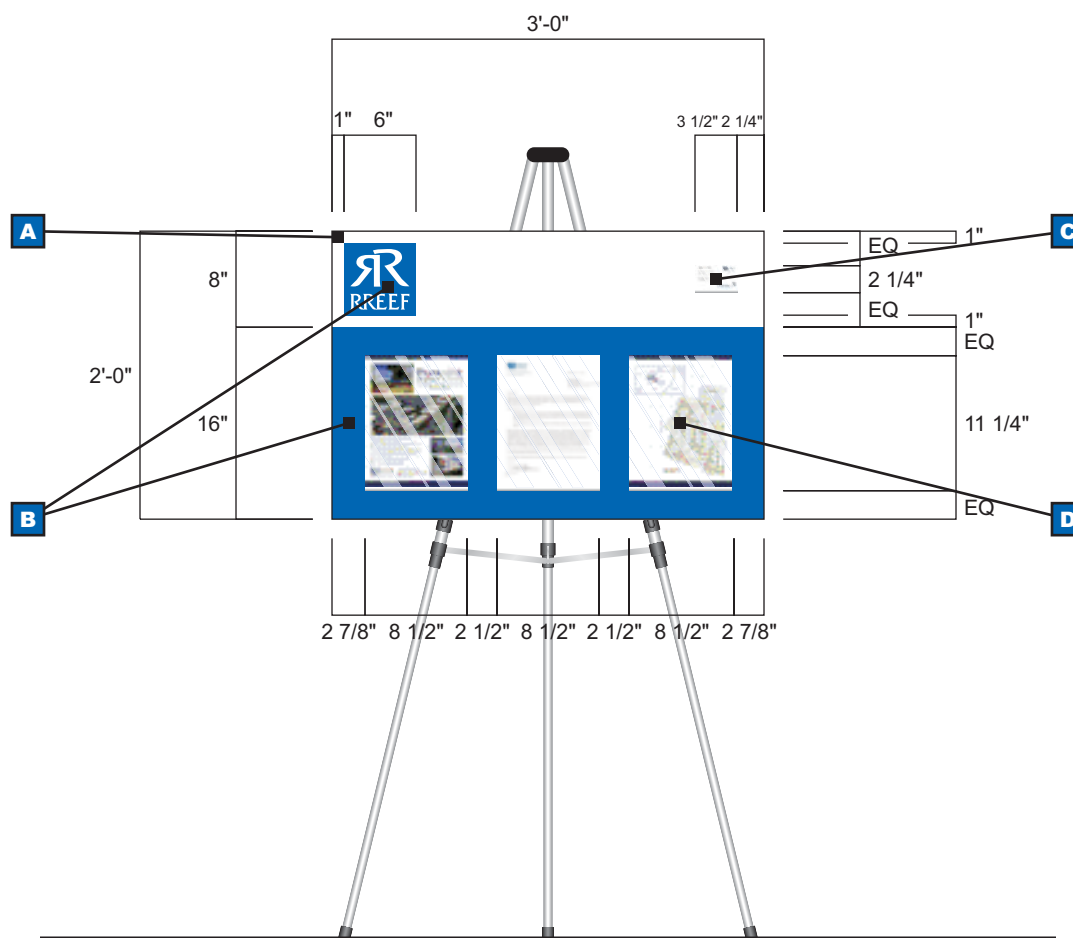

Typical RREEF Marketing Display Board

Specifications:

- A** 1/8" matte clear acrylic back with #220-10 White 3M Scotchcal Premium Vinyl Film applied to the rear surface.
- B** #220-37 Sapphire Blue 3M Scotchcal Premium Vinyl Film applied to the rear surface.
- C** Heat-folded 1/8" clear acrylic business card holder adhered to back with Weld-On adhesive.
- D** Heat-folded 1/8" clear acrylic 8 1/2" x 11" displays (3 each) adhered to back with Weld-On adhesive.

C1.1



Photo to be added later.

Typical RREEF Marketing Display Board Photo



RREEF Entrance Mats

General Requirements:

Entrance mats should be placed inside the main entrance to all RREEF vacancies giving a professional look to the space when it is shown to potential tenants. When a space is leased, either move the mat to a new vacant space or leave it for the new tenant.

Entrance mats are also required to be placed inside the front entrance to all RREEF management offices.

3' x 5' entrance mats must be used inside a double-door and 2' x 3' entrance mats must be used inside a single-door.

4' x 6' and 5' x 8' mats may also be used when appropriate.

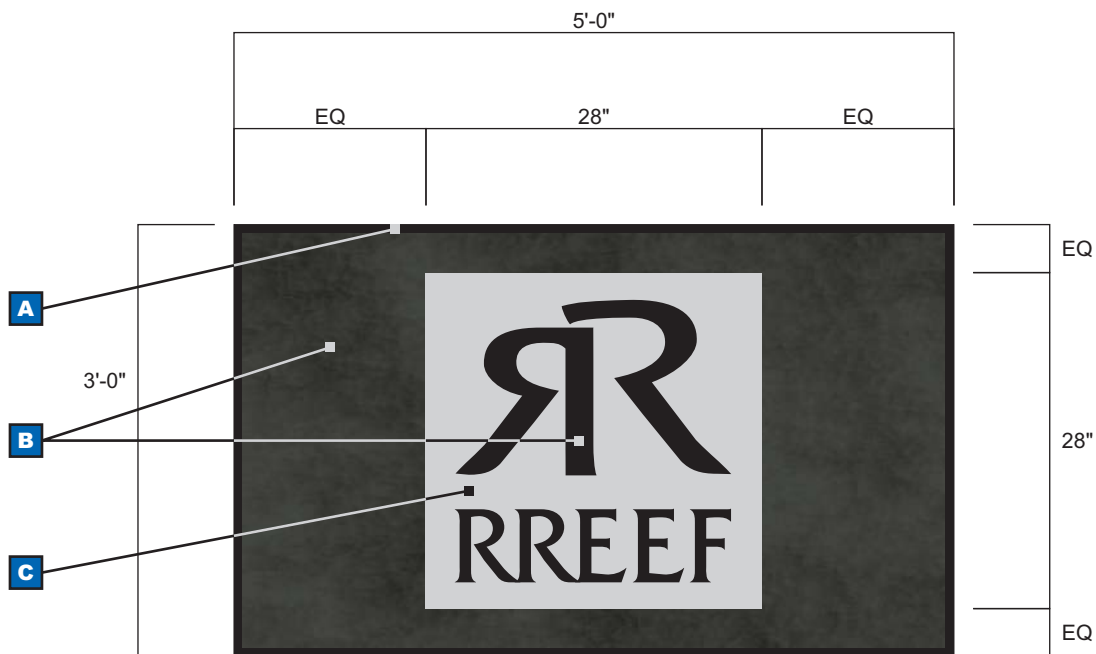

Typical 3' x 5' Entrance Mat

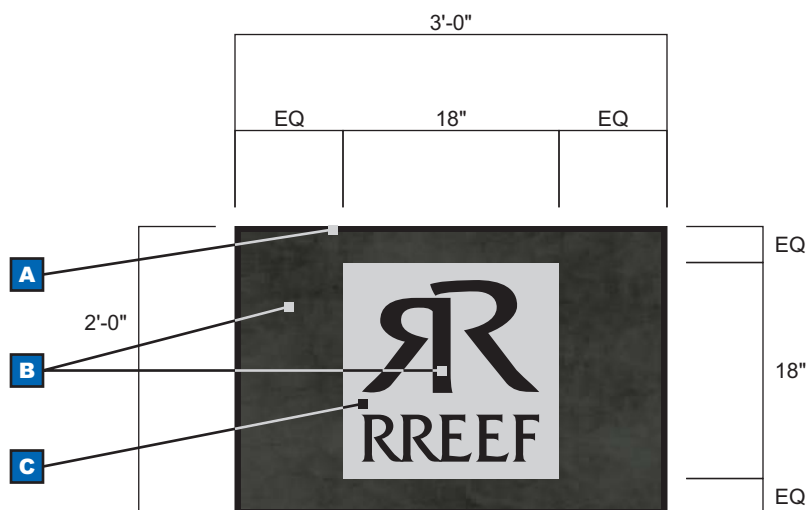

Typical 2' x 3' Entrance Mat

Specifications:

- A** Black rubber backing and border.
- B** #401 Black static dissipative nylon.
- C** #418 Silver static dissipative nylon, sewn in by computer.



Typical Entrance Mat Photo



RREEF Leasing Banners

General Requirements:

These are to be used on building walls facing a freeway or a major highway.

The banner must be installed using the methods indicated on page C3.3. No ropes are to be used.

Banner sizes may be 4' x 16' or 6' x 24' but should remain proportional.

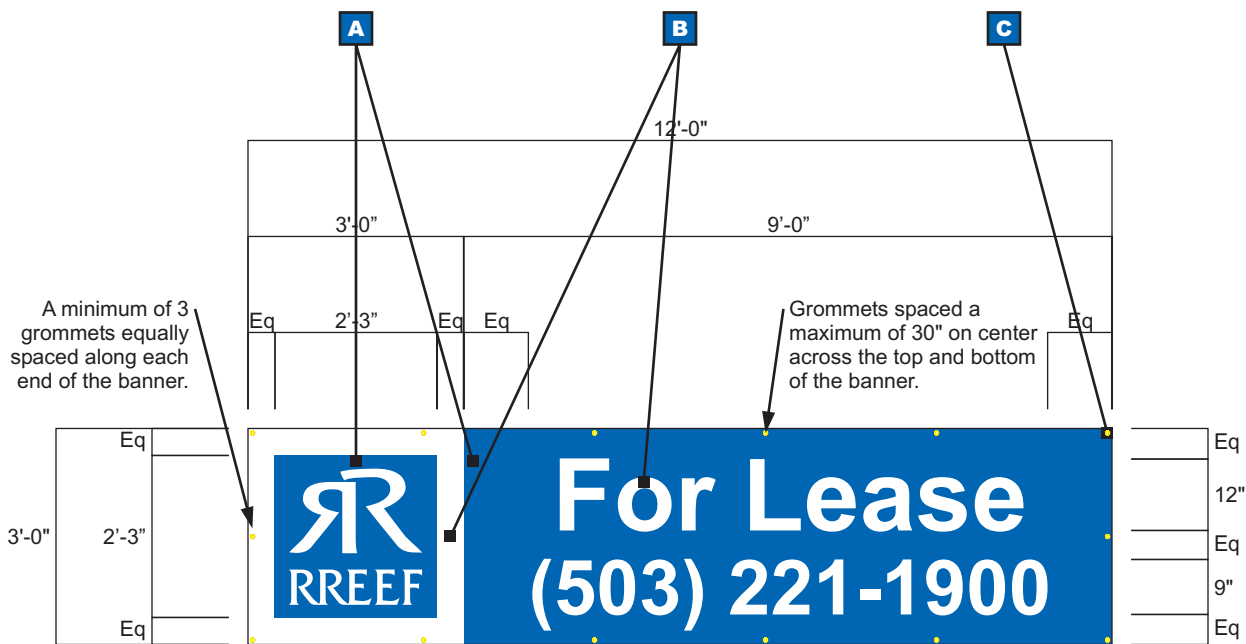

Typical RREEF Leasing Banner

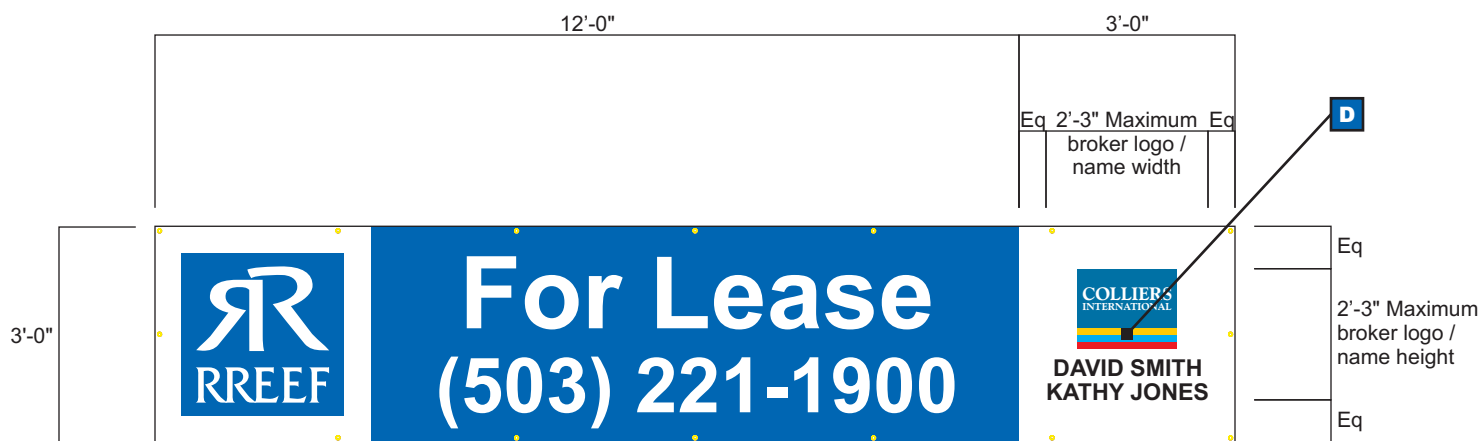

Alternative Layout with Broker Information

Specifications:

- A** 300 dpi full bleed digital print with U. V. resistant ink to match PMS 287C Blue.
- B** 14 oz. white vinyl banner (copy shows thru digital print).
- C** #2 brass grommets.
- D** 300 dpi digital print in Broker's own colors.



Photo to be added later.

Typical Banner Photo

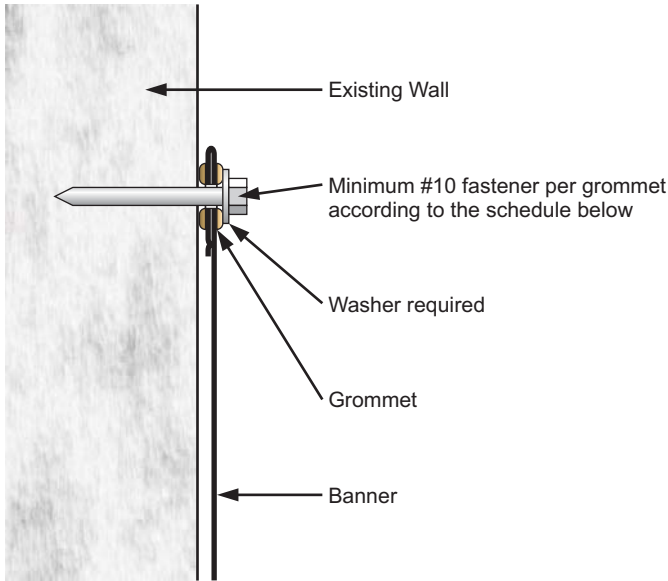

Banner Section Installation Detail

For installations on buildings at 3 stories high or less.

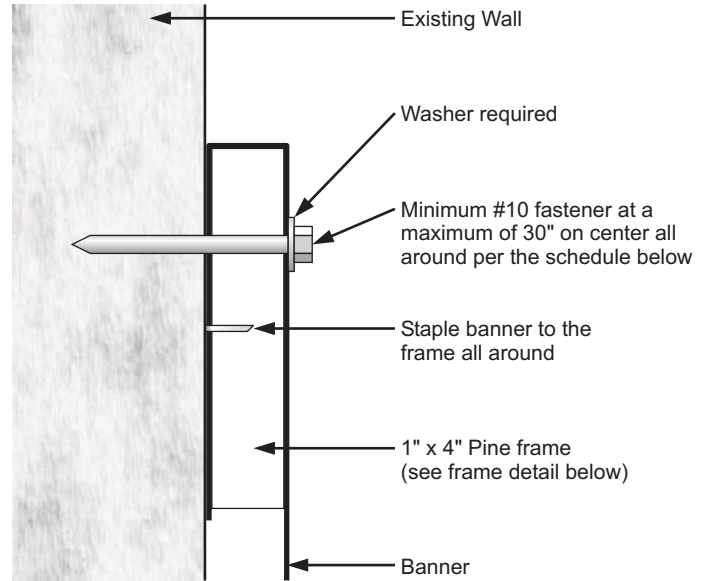

Banner Section Installation Detail

For installations on buildings at 4 stories high or higher.

Fastener Schedule		
Wall Type	Fastener Type	Instructions
Stucco	#10 x 1" hex-head screw with a plastic shield	Drill hole into stucco, insert plastic shield & drive screw into shield.
EIFS	3/16" x 4" (or longer) toggle bolt	Drill oversize hole thru foam substrate and plywood or gypsum backing, insert toggle & tighten.
Wood	#10 x 1" hex-head screw	Drive screw into wood.
Concrete	#10 x 1" hex-head screw with a plastic shield	Drill hole into concrete, insert plastic shield & drive screw into shield.
Masonry	#10 x 1" hex-head screw with a plastic shield	Drill hole into masonry, insert plastic shield & drive screw into shield.

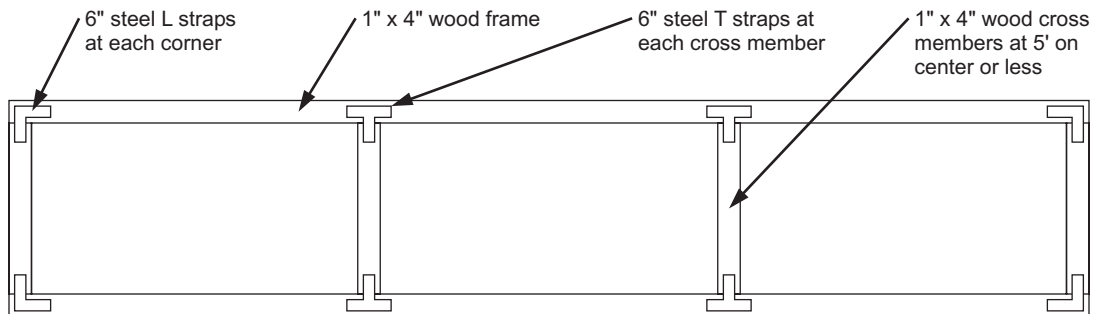

Frame Detail

General Requirements:

These are to be placed inside vacant units with sufficient directional information to assist in locating the warehouse lights.

Place these in a conspicuous location just inside the entrance door to the unit so as to be easily and immediately noticed.

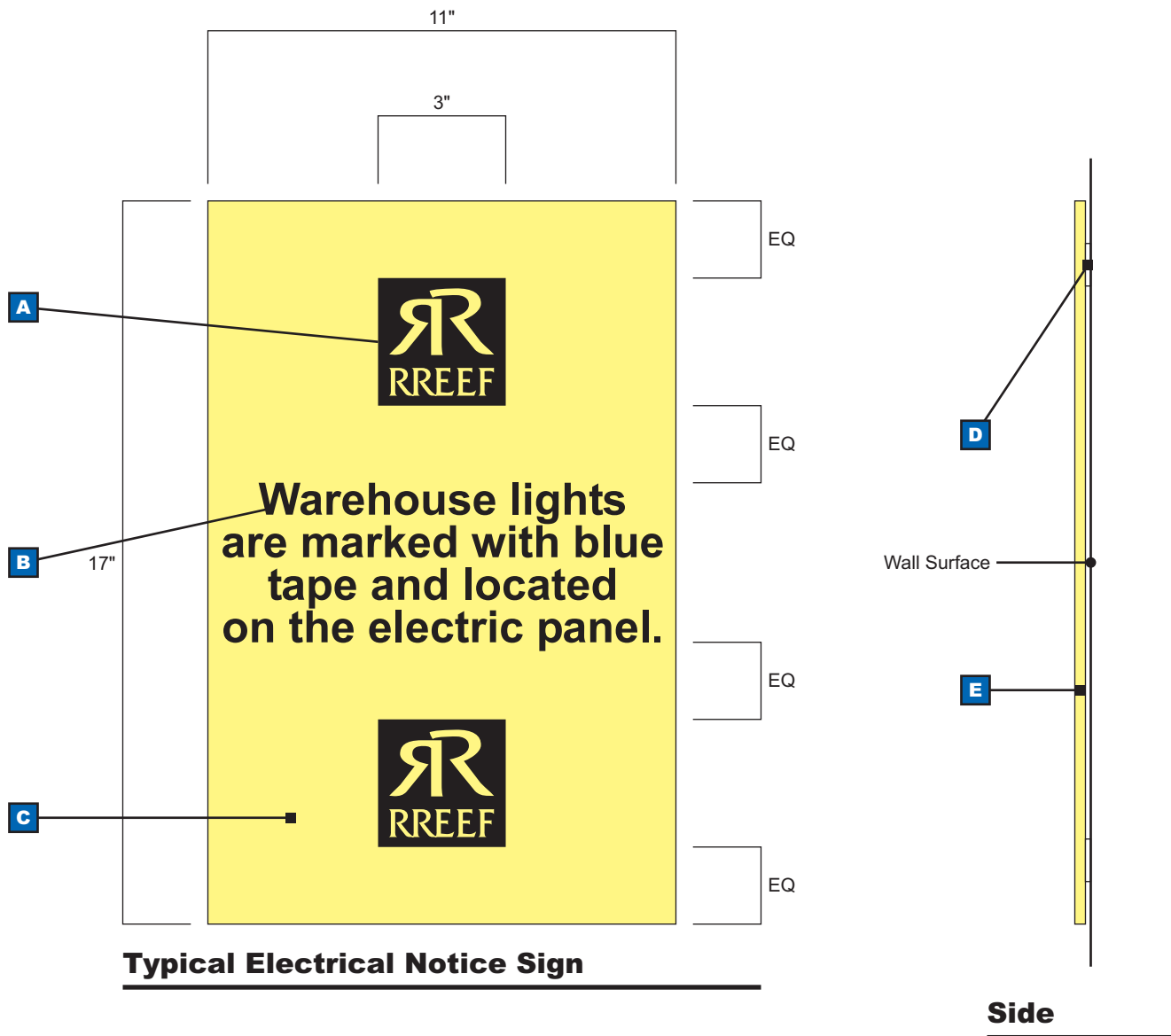

Specifications:

- A** Black 400 dpi laser printed logo.
- B** Black 400 dpi laser printed 3/4" Arial Bold Text.
- C** 11" x 17" yellow fluorescent paper with a clear plastic laminate applied to back with spray adhesive.
- D** 1/8" x 1" Scotch brand heavy duty mounting tape at top and bottom.
- E** 1/4" White foam core board.

Photo to be added later.

Typical Electrical Notice Sign Photo

General Requirements:

These may be used on any extra flag poles but should not take the place of or share the same pole as a State Flag or the flag of the United States of America.

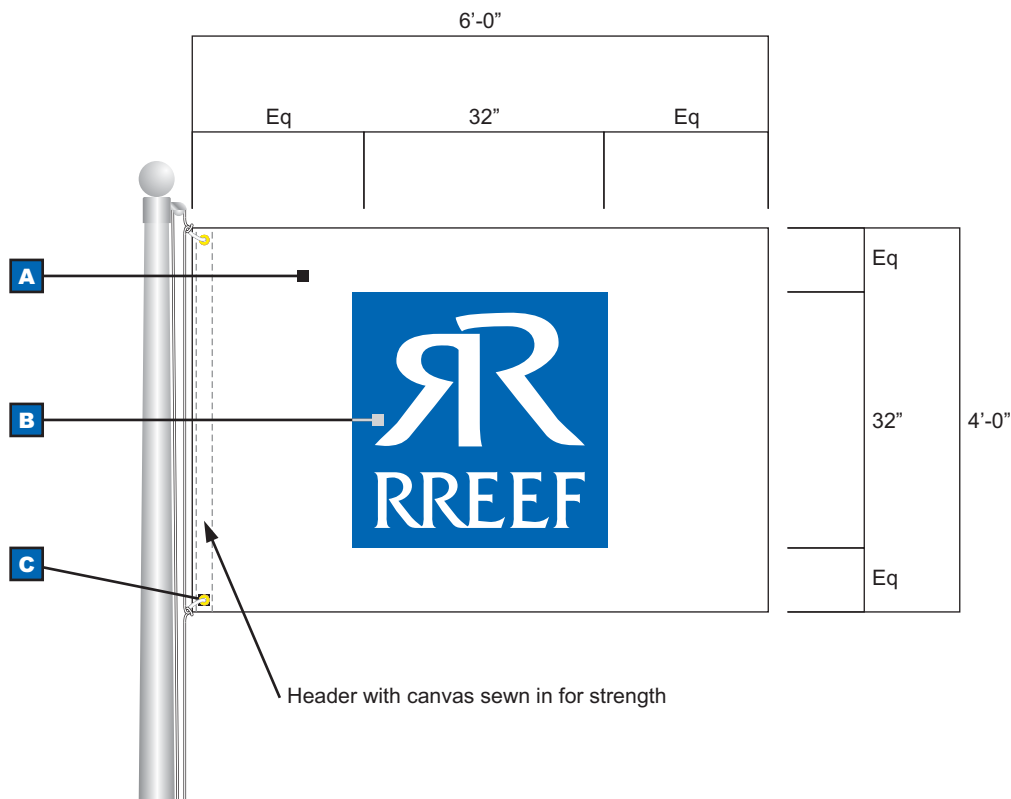

Typical 4' x 6' Flag

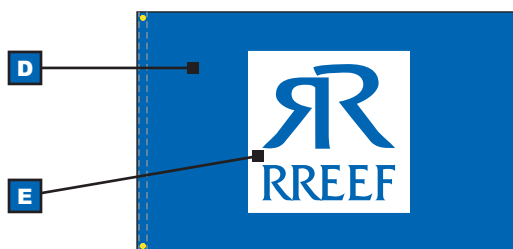

Alternative Colors

Specifications:

- A** White Polyester material.
- B** Royal Blue digital print to match PMS 287 Blue (one-sided or two-sided).
- C** #2 Brass Grommets.
- D** Royal Blue Polyester material.
- E** White silk-screened print (one-sided or two-sided).

General Requirements:

These may be used on any extra flag poles but should not take the place of or share the same pole as a State Flag or the flag of the United States of America.

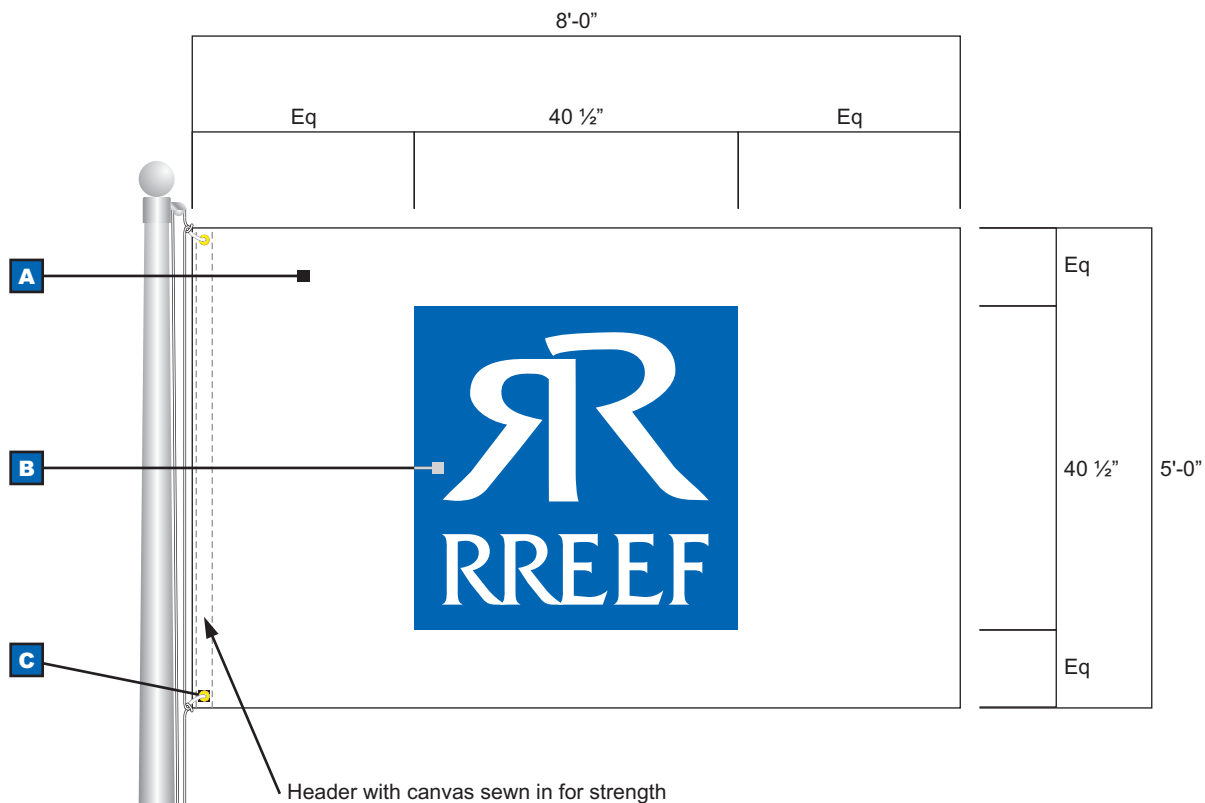

Typical 5' x 8' Flag

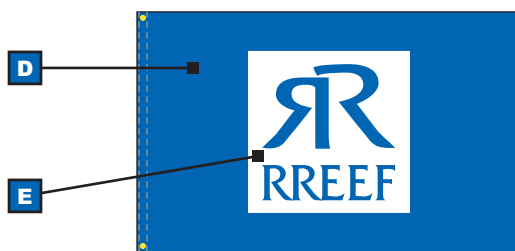

Alternative Colors

Specifications:

- A** White Polyester material.
- B** Royal Blue digital print to match PMS 287 Blue (one-sided or two-sided).
- C** #2 Brass Grommets.
- D** Royal Blue Polyester material.
- E** White silk-screened print (one-sided or two-sided).



Section D:

Office Building Signs



Section D Table of Contents

Sections:

A The RREEF Corporate Logo, Colors & Typefaces

B Property Management Marketing Signs

C Property Management Marketing Materials

D Office Building Signs

E On-Site Management / Leasing Office Signs

Office Building Signs

Page: Description:

D1.1	RREEF Individual Entrance Door Logos
D1.2	RREEF Individual Entrance Door Logos Layout Options
D1.3	RREEF Individual Entrance Door Logo Photo
D2.1	RREEF Inline Entrance Door Logos & Layout
D2.2	RREEF Inline Entrance Door Logo Photo
D3.1	Emergency Information
D3.2	Emergency Information Layout Options
D3.3	Emergency Information Photo
D4.1	Directory Leasing Information
D4.2	Directory Leasing Information Layout Options
D4.3	Office Building Directory Photo



RREEF Individual Entrance Door Logos

General Requirements:

Managers should use discretion when applying Entrance Door Logos. If there is an existing project identification present (i.e.; IDS Center or Citicorp Center), do not replace it with a RREEF logo. In this case, a RREEF logo may be placed above Emergency Information as shown on page D3.1.

Either Color Option A or B (below) may be used.

Use the most appropriate Layout Option as shown on page D1.2.

Either Individual or Inline Entrance Door Logos (D2.1) may be used.

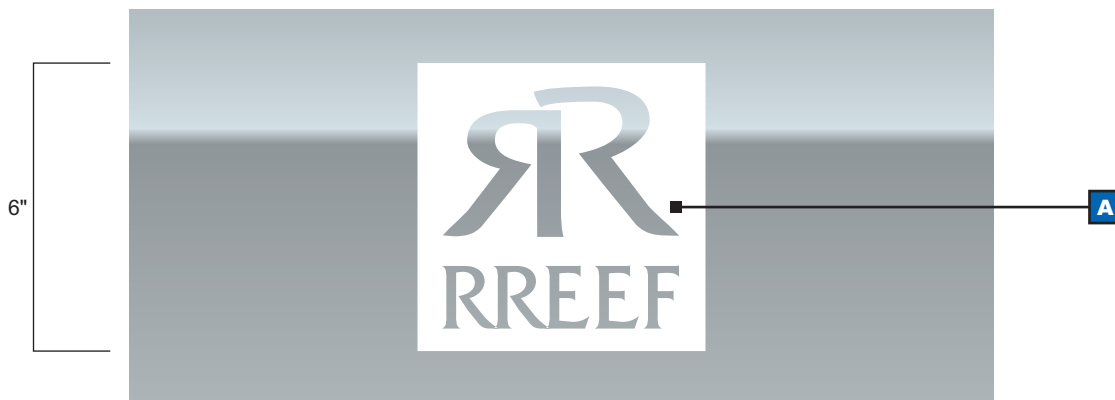

Individual Entrance Door Logo - Color Option A

15"

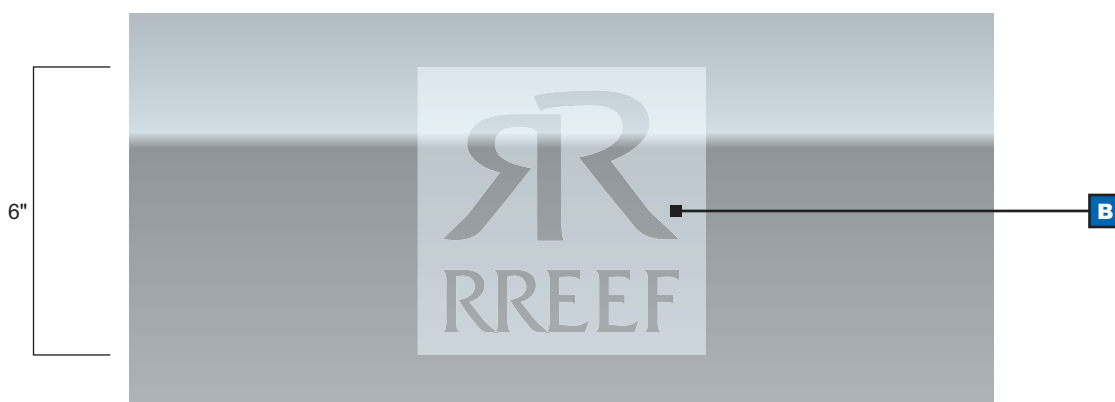

Individual Entrance Door Logo - Color Option B

Specifications:

A #220-10 3M high performance white vinyl.*

B #210-314 3M translucent Dusted Crystal vinyl.*

* Always apply on the inner surface of glass unless it is tinted.

D1.1

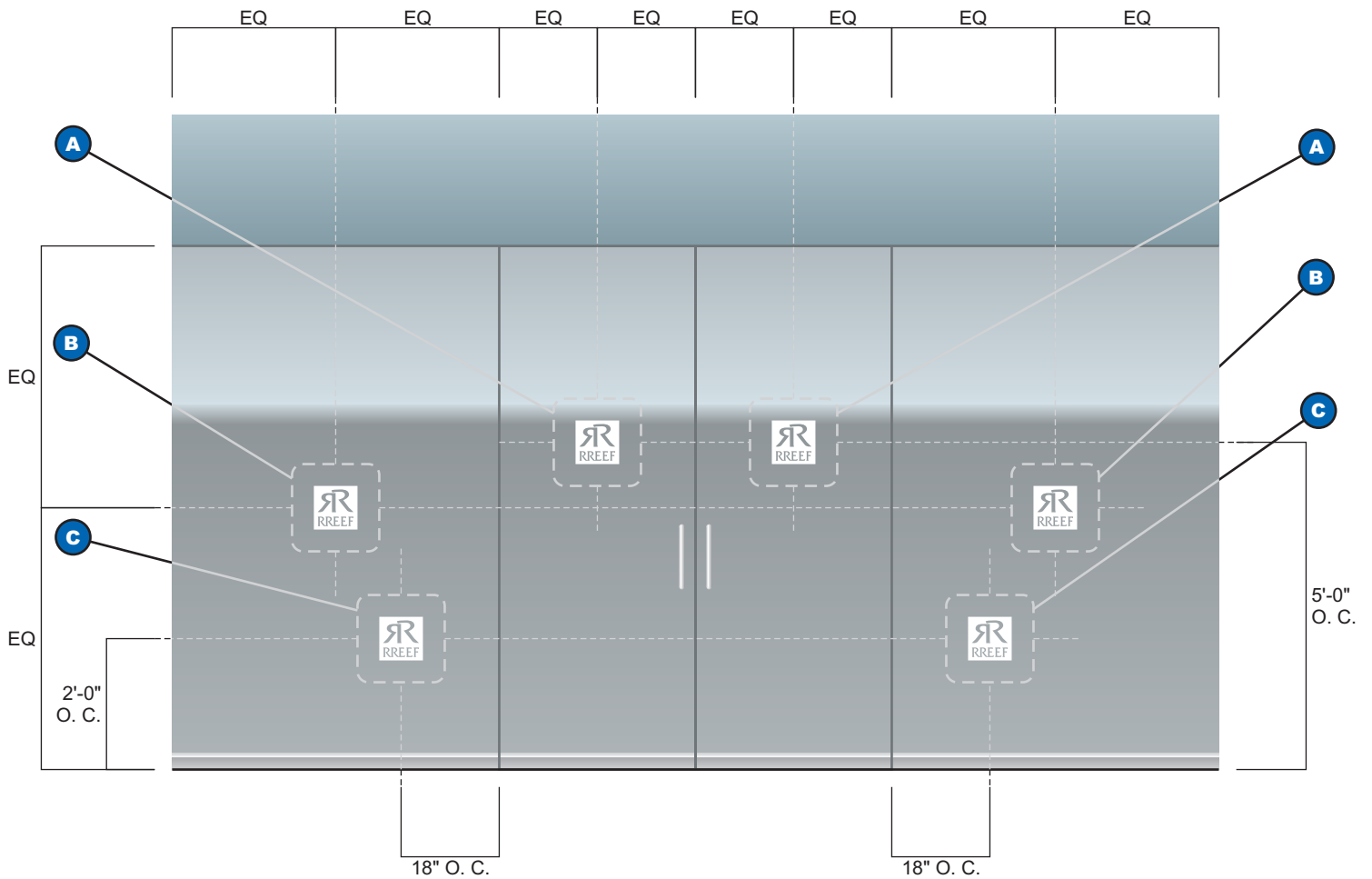

Typical Office Building Entrance

Layout Options:

- A Obvious:** Place one logo on each door.
- B Less Obvious:** Place one logo on each glass panel adjacent to the doors.
- C Inconspicuous:** Place one logo on each glass panel adjacent to the doors at a lower level.



Typical Individual Entrance Door Logo Photo



RREEF Inline Entrance Door Logos & Layout

General Requirements:

Managers should use discretion when applying Entrance Door Logos. If there is an existing project identification present (i.e.; IDS Center or Citicorp Center), do not replace it with a RREEF logo. In this case, a RREEF logo may be placed above Emergency Information as shown on page D3.1.

Either Color Option A or B (below) may be used.

Either Individual (D1.1) or Inline Entrance Door Logos may be used.

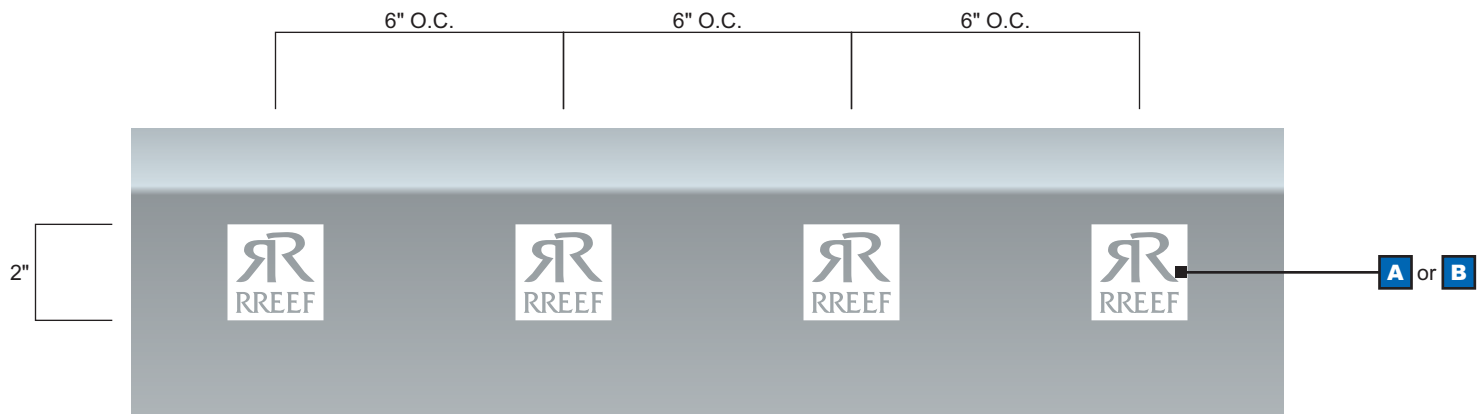

Inline Entrance Door Logos

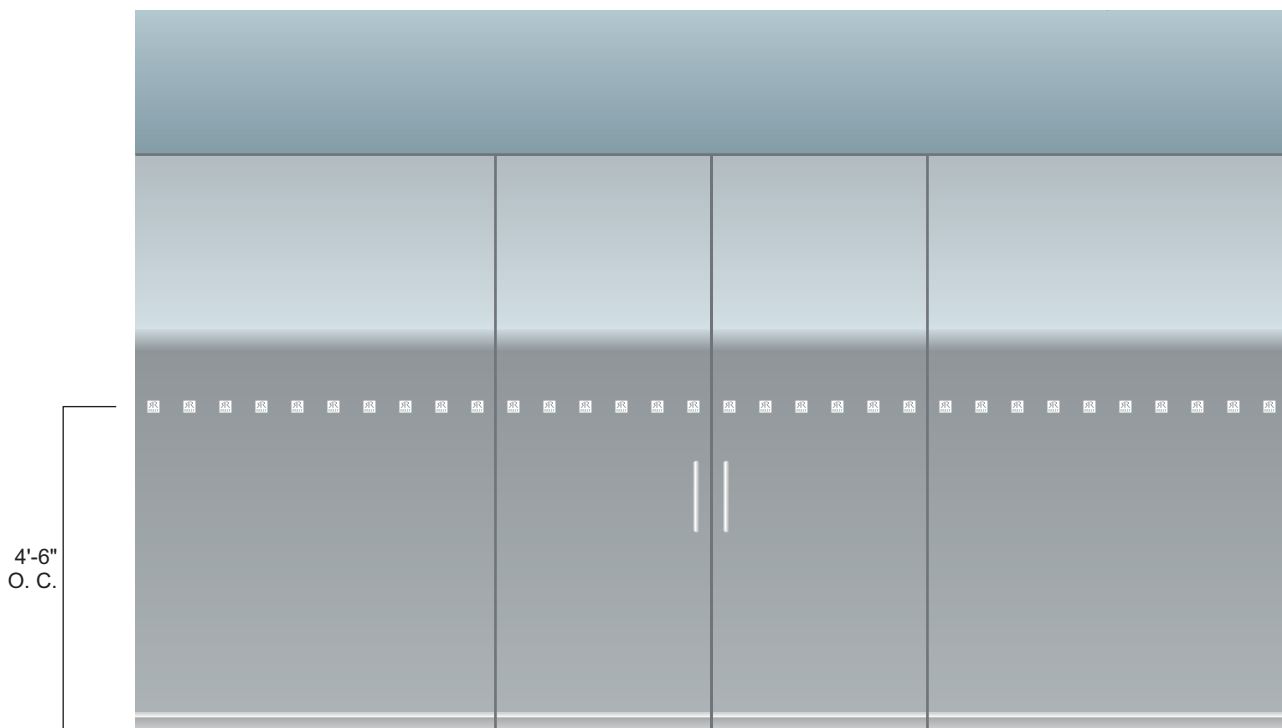

Typical Office Building Entrance

Specifications:

A #220-10 3M high performance white vinyl.*

B #210-314 3M translucent Dusted Crystal vinyl.*

* Always apply on the inner surface of glass unless it is tinted.

D2.1



Typical Inline Entrance Door Logos Photo



Emergency Information

General Requirements:

Emergency information should always be listed at the front entrance of office buildings.

Always use the RREEF logo (see below and Option B on page D3.2) unless a RREEF Entrance Door Logo has already been applied.

Emergency information should always be applied to the left glass panel if possible.

Business hours may be included with either option unless posted elsewhere.

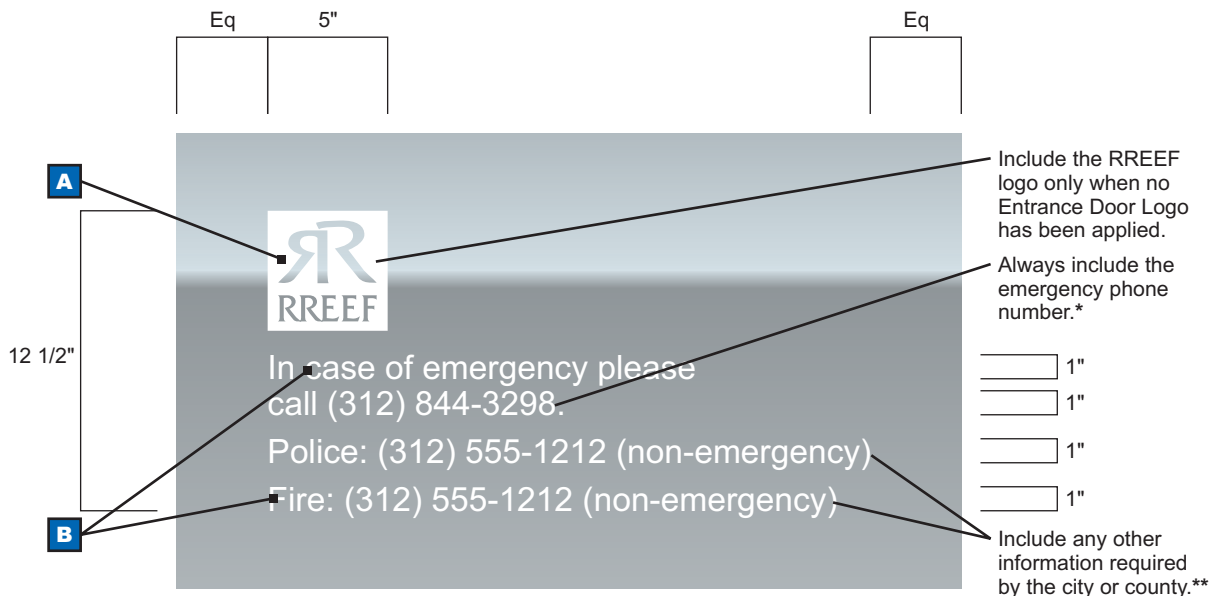

Emergency Information with RREEF Logo

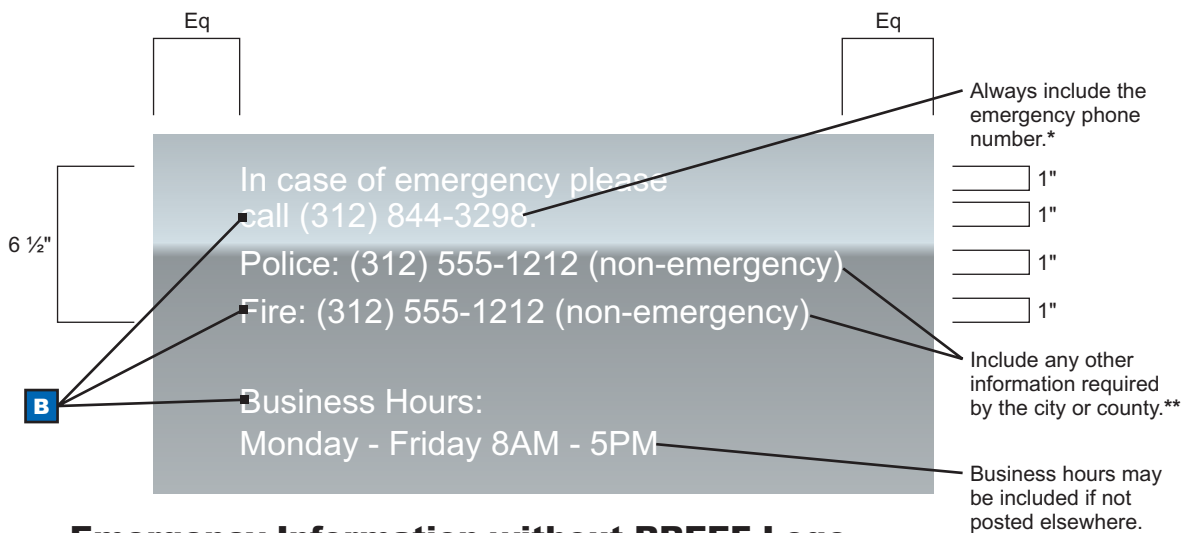

Emergency Information without RREEF Logo

*Can be a Patrol Service, Answering Service or however an employee can be reached after hours.

**All Police or Fire numbers listed must have the words "(non-emergency)" added for liability reasons.

Specifications:

A #220-10 3M high performance white vinyl or #210-314 3M translucent Dusted Crystal vinyl.*

B #220-10 3M high performance white vinyl or #210-314 3M translucent Dusted Crystal vinyl* in Ariel font.

* Always apply on the inner surface of glass unless it is tinted.



Emergency Information Layout Options

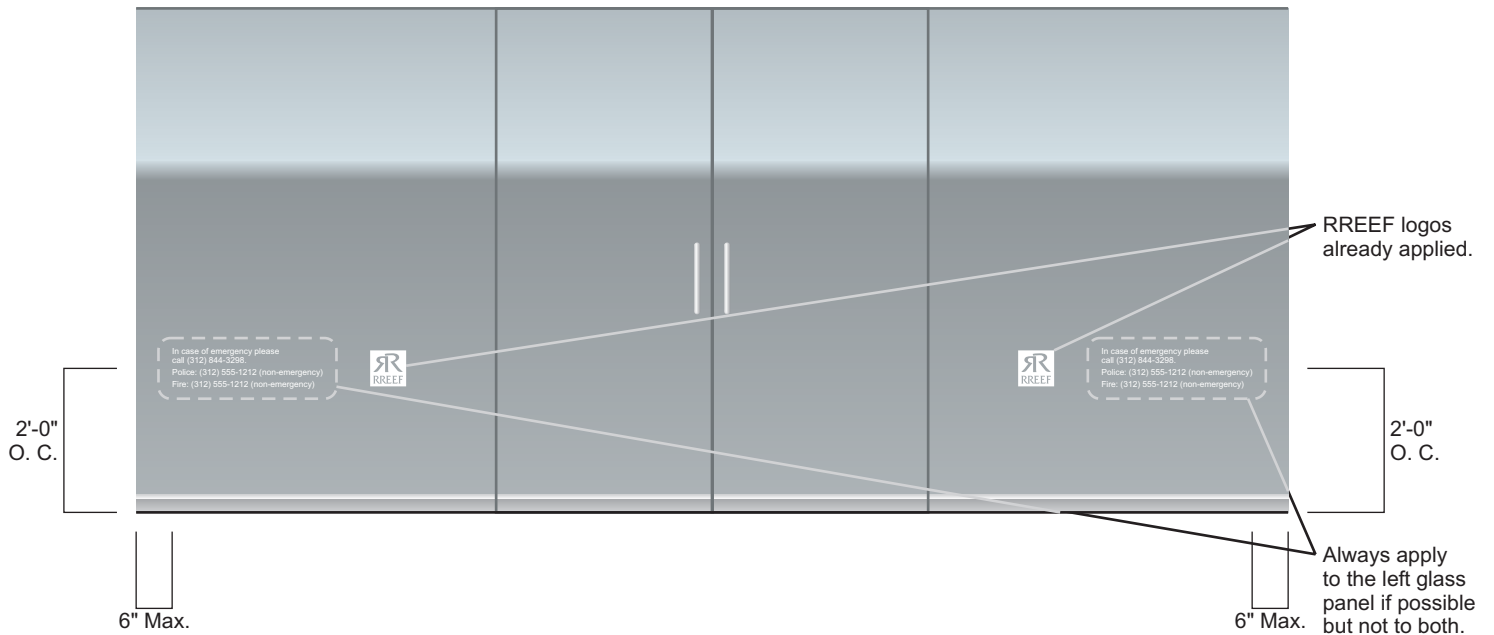

Office Building Entrance with Entrance Door Logo already applied - Option A

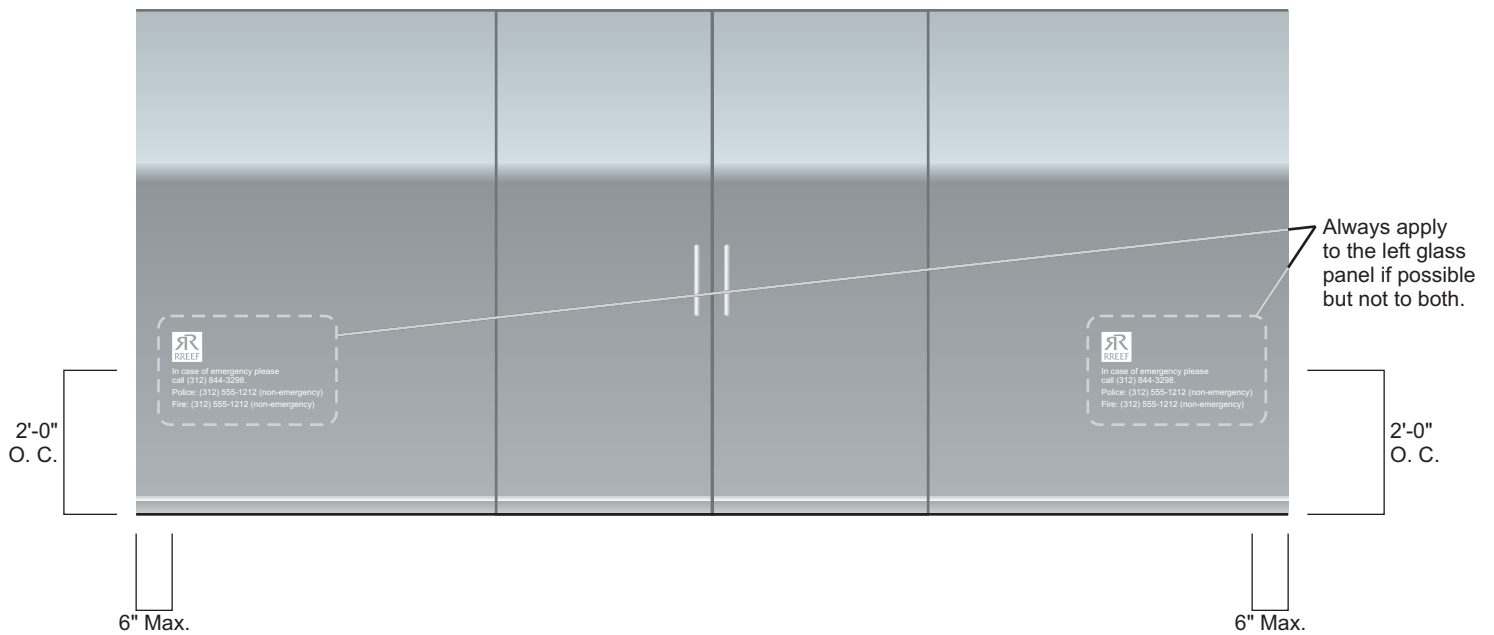

Office Building Entrance without Entrance Door Logo already applied - Option B



Typical Emergency Information Photo



Typical RREEF Directory Leasing Information Layout

* "R" is a distance equal to the height of the RREEF logo.

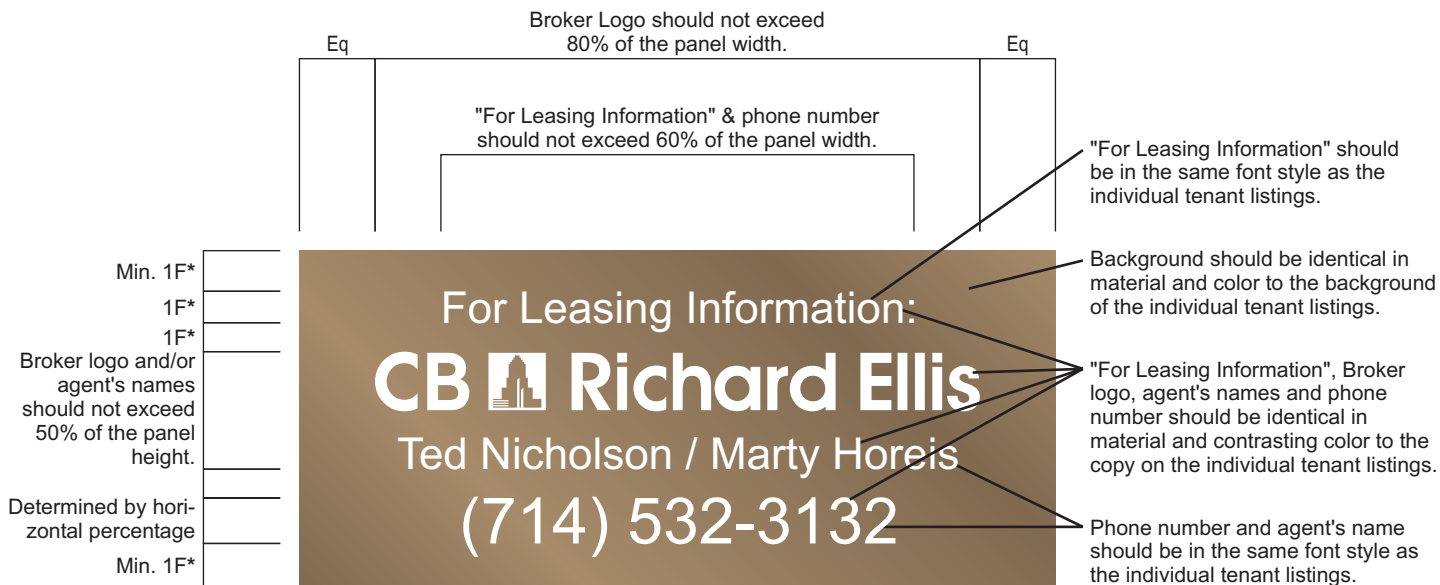

Typical Broker Directory Leasing Information Layout

* "F" is a distance equal to the height of the F in "For Leasing Information".



Typical Office Building Directory Photo



Section E:

On-Site Management / Leasing Office Signs



Section E Table of Contents

Sections:

A The RREEF Corporate Logo, Colors & Typefaces

B Property Management Marketing Signs

C Property Management Marketing Materials

D Office Building Signs

E On-Site Management / Leasing Office Signs

On-Site Management / Leasing Office Signs

Page: Description:

E1.1	Leasing Office Directional Signs
E1.2	Leasing Office Directional Sign Photo
E1.3	Layout Options & Placement Detail
E1.4	Panel Attachment and Installation Details
E2.1	Leasing Office Exterior Wall Identification
E2.2	Exterior Wall Identification Elevation & Photo
E3.1	Leasing Office Window & Door Graphics
E3.2	Leasing Office Window Graphics Photo
E4.1	Leasing Office Emergency Information
E4.2	Emergency Information Placement
E5.1	Leasing Office Impact Wall Graphic
E5.2	Leasing Office Impact Wall Graphic Options
E5.3	Leasing Office Impact Wall Graphic Photo
E6.1	Building Directory
E6.2	Contact Information Layout
E7.1	Leasing Office Flags
E7.2	Leasing Office Flag Photo

General Requirements:

This sign is to be used for all on-site leasing offices located in office or industrial parks.

Signs should be placed throughout the property so that anyone can easily find this destination from any direction.

Signs may be double-faced or single-faced but should be made according to the Typical Layout Options on page E1.3.

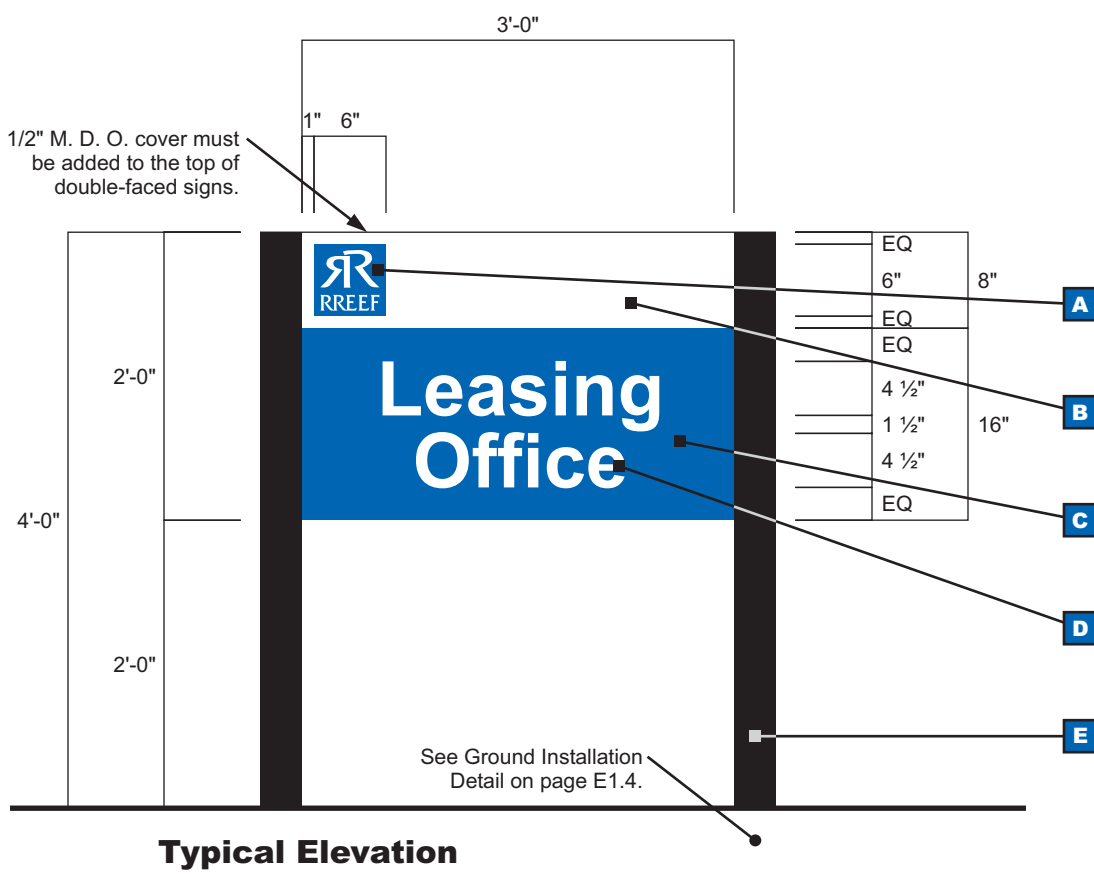

Specifications:

- A** #220-37 Sapphire Blue 3M Scotchcal Premium Vinyl Film.
- B** 3/4" Single-Sided M. D. O. Panel* with #101 White 1-Shot Graphic Coat Bulletin Enamel finish.
- C** Background area painted with 1-Shot Graphic Coat Bulletin Enamel finish to match PMS 287C.**
- D** #220-10 White 3M Scotchcal Premium Vinyl Film. Font must be Arial Bold.
- E** 4" x 4" Grade 2 or Better Douglas Fir Posts stained with Black Sherwin Williams Woodscapes Solid Stain.***

*All M. D. O. panels are to be sealed and primed on front surface and edges with 1-Shot 5005 Acrylic Bonding Primer prior to finish coat. Face color is to be returned around adjacent edges. Rear surfaces of single-sided or v-shaped signs are to be stained with Black Sherwin Williams Woodscapes Solid Stain. Double-face signs should incorporate 2 single-sided panels back to back (see B1.4).

**Corresponding color is #155 1-Shot Reflex Blue.

***All posts must be stained completely on all surfaces before below ground installation.



RREEF Leasing Office Directional Sign Photo

Typical Layout Options:

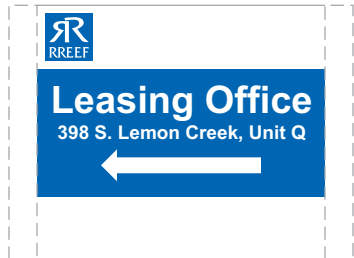

Sign Type A with Address and Arrow



Sign Type B with Arrow



Sign Type C without Arrow

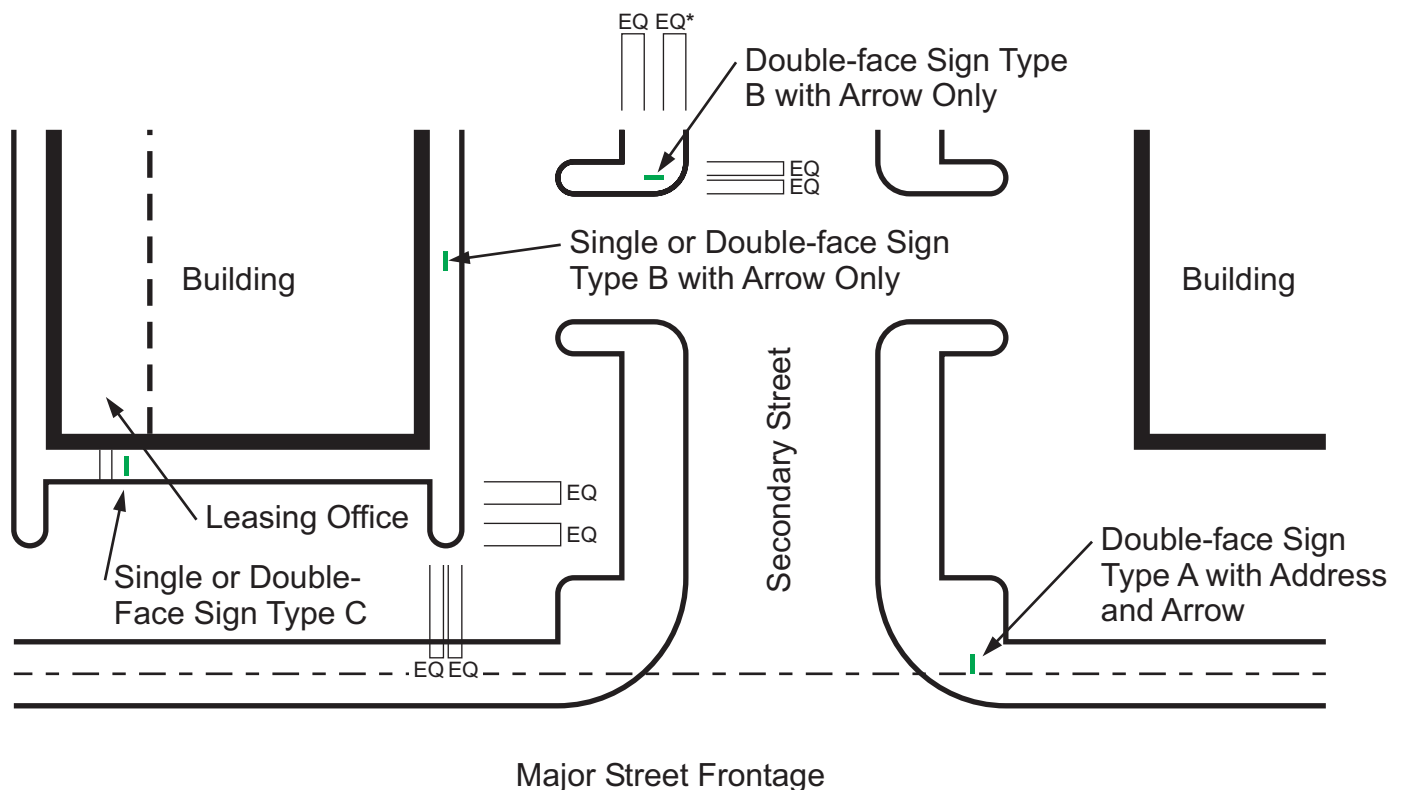

Typical Office Directional Sign Placement Detail

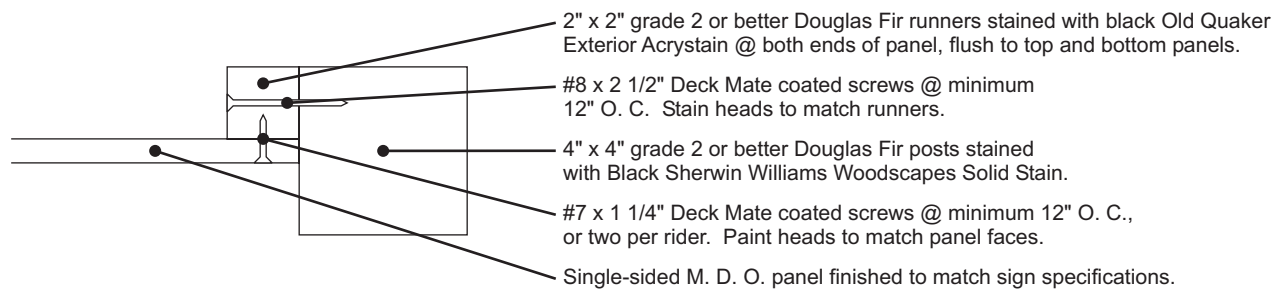

Panel Attachment Detail for Single-Faced Version

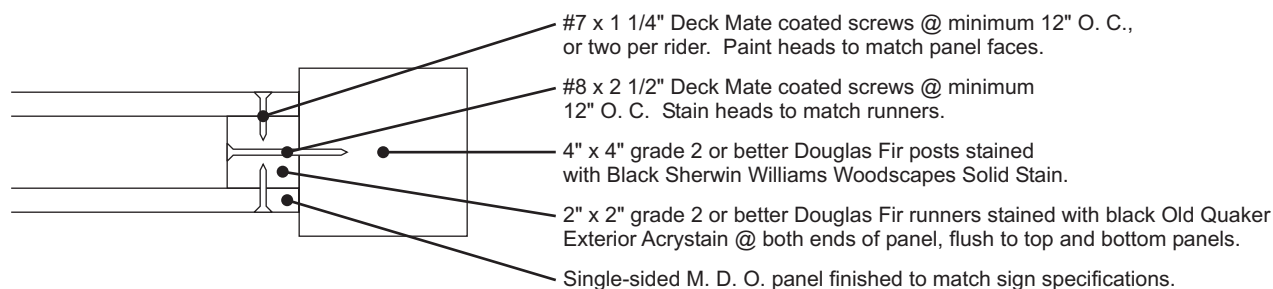

Panel Attachment Detail for Double-Faced Version

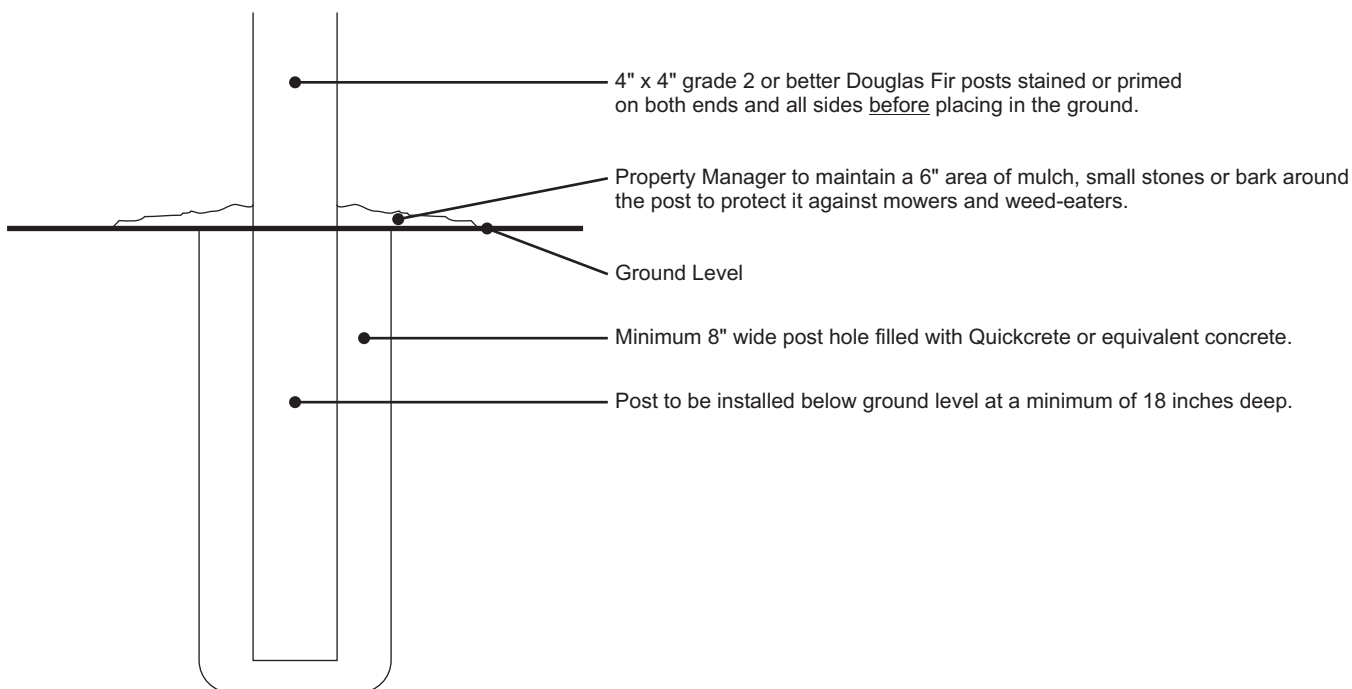

Ground Installation Detail



Leasing Office Exterior Wall Identification

General Requirements:

This sign is to be used for all on-site leasing offices located in RREEF owned office or industrial parks.

Signs should be made according to the standards below unless they are required to match an existing property sign criteria.

Signs should be centered upon the wall fascia above the main entrance door as shown on the Typical Leasing Office Entrance Elevation on page E2.2.

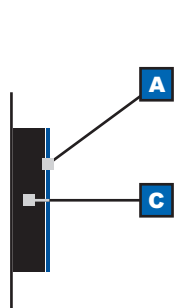
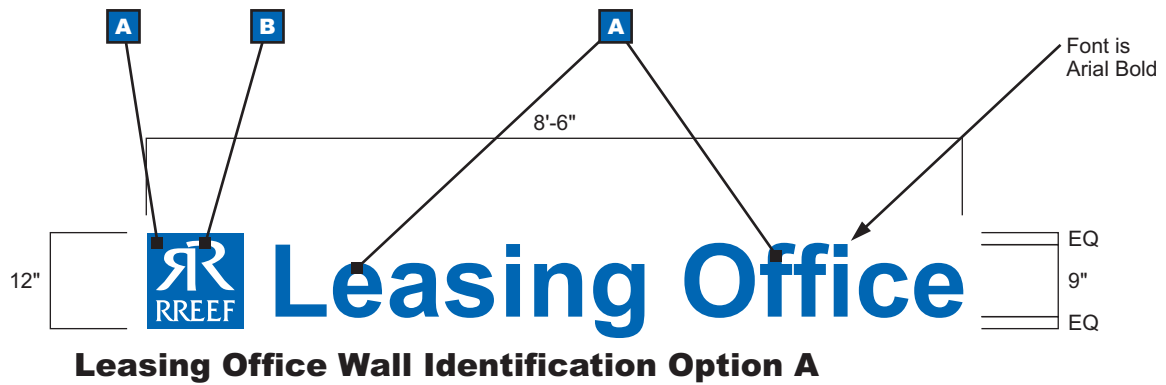

Enlarged Side View

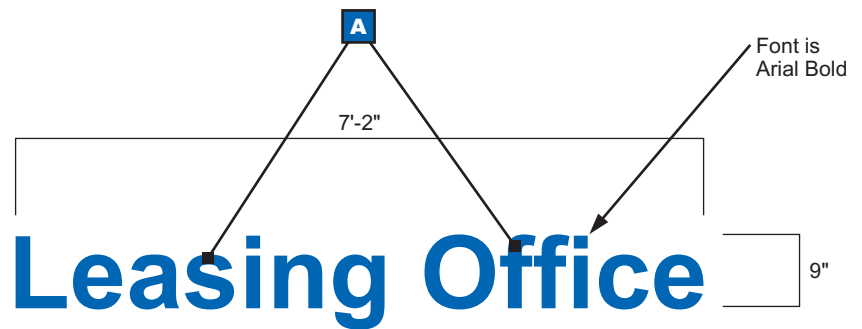

Leasing Office Wall Identification Option B

Specifications:

A 1/8" #606-0 GP Dark Blue Acrylite acrylic laminated to foam backs using 100% silicone adhesive applied with a continuous coat to cover entire surfaces between pieces.

B #220-10 White 3M Scotchcal Premium Vinyl Film.

C 2" deep high-density foam painted with flat black Ronan Aquatone water-based paint. Letters are then adhered to the building wall using 100% clear silicone adhesive together with Scotch brand heavy duty foam mounting tape.

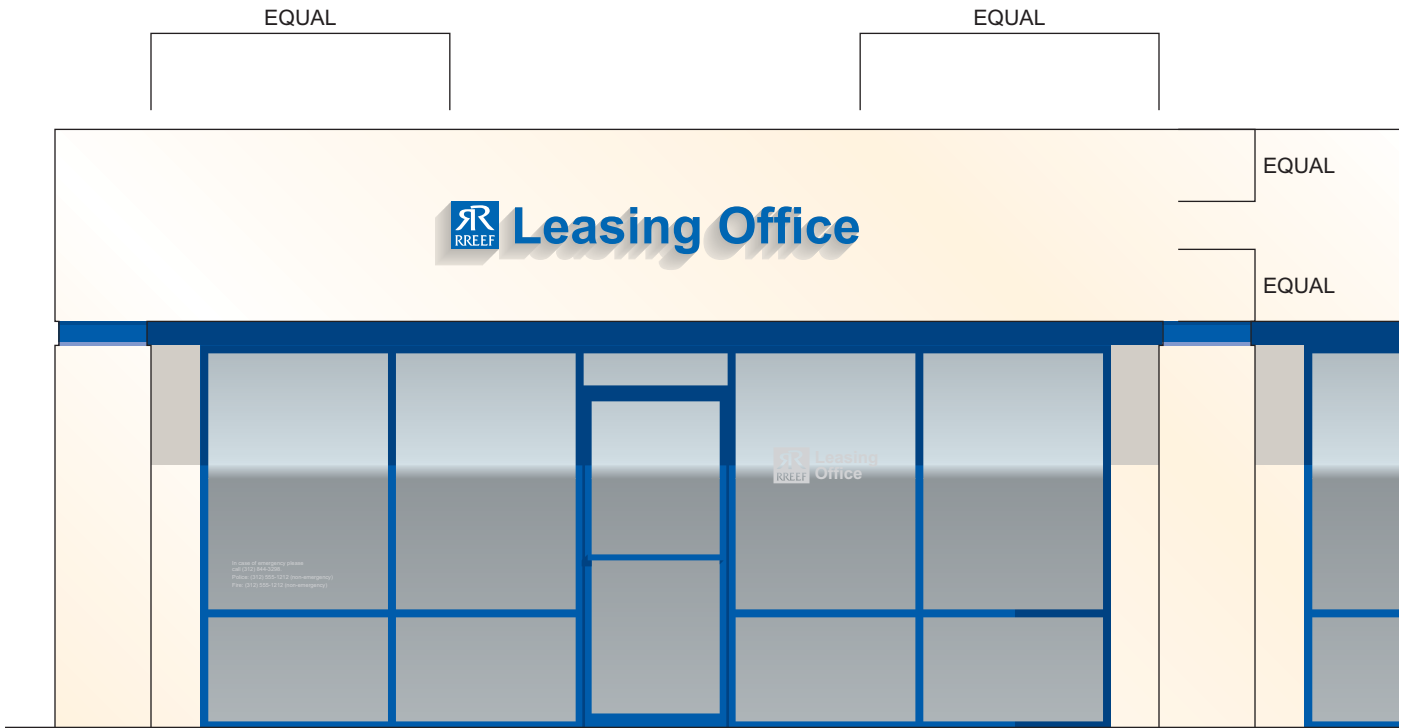

Typical Leasing Office Entrance Elevation

Photo to be added later.

Typical Leasing Office Wall Identification Photo



Leasing Office Window & Door Graphics

General Requirements:

This sign is to be used for all on-site leasing offices located in office or industrial parks.

Signs should be made according to the standards below unless they are required to match an existing property sign criteria.

26" or a maximum of 75% of the width of the glass, or the maximum size allowed by the property sign criteria, whichever is least.



Leasing Office Window & Door Graphics

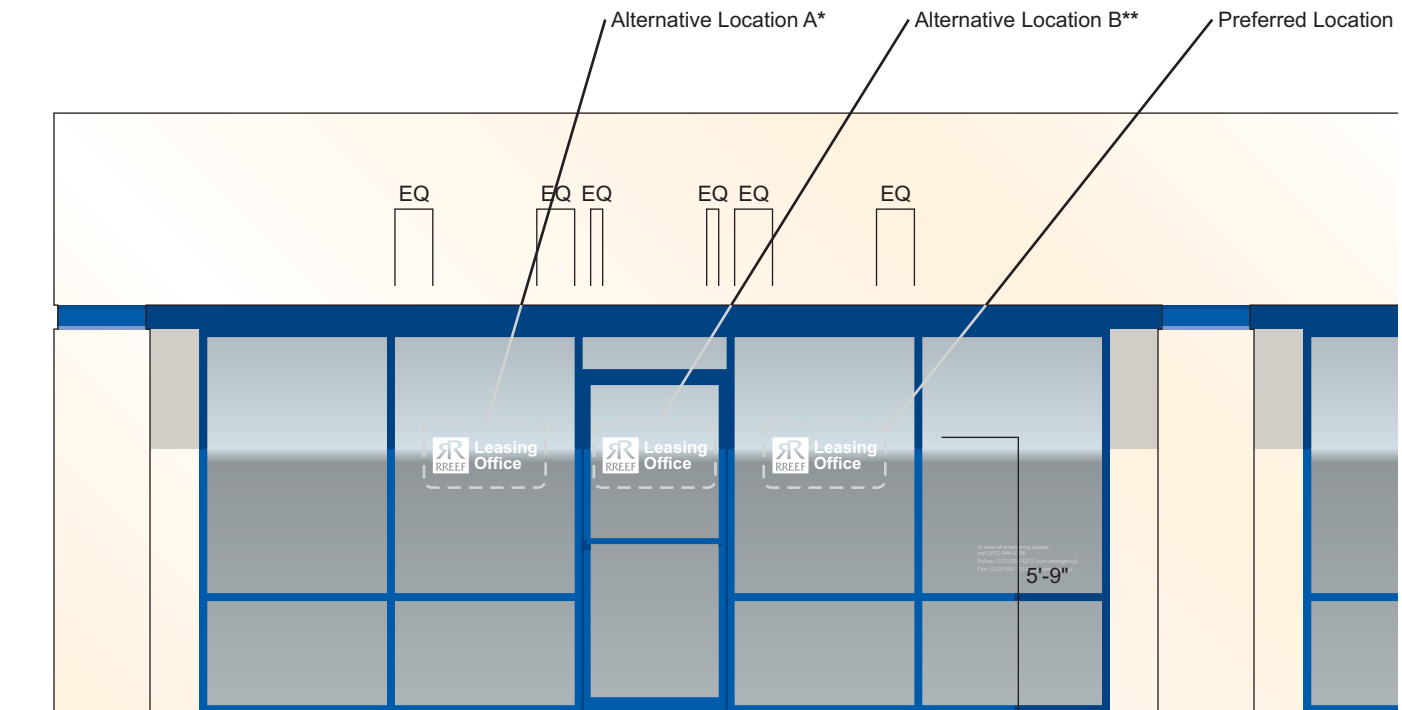

Typical On-Site Leasing Office Entrance

*Use only when no right side window exists.

**Use only when no right or left side window exists.

Specifications:

A #220-10 3M high performance white vinyl film or as required by the property sign criteria.*

* Always apply on the inner surface of glass unless it is tinted.

E3.1

Photo to be added later.

Typical Leasing Office Window Graphics



Leasing Office Emergency Information

General Requirements:

This sign is to be used for all on-site leasing offices located in office or industrial parks.

Signs should be made according to the standards below unless they are required to match an existing property sign criteria.

These should always be placed according to the Typical Leasing Office Elevation shown on page E4.2.

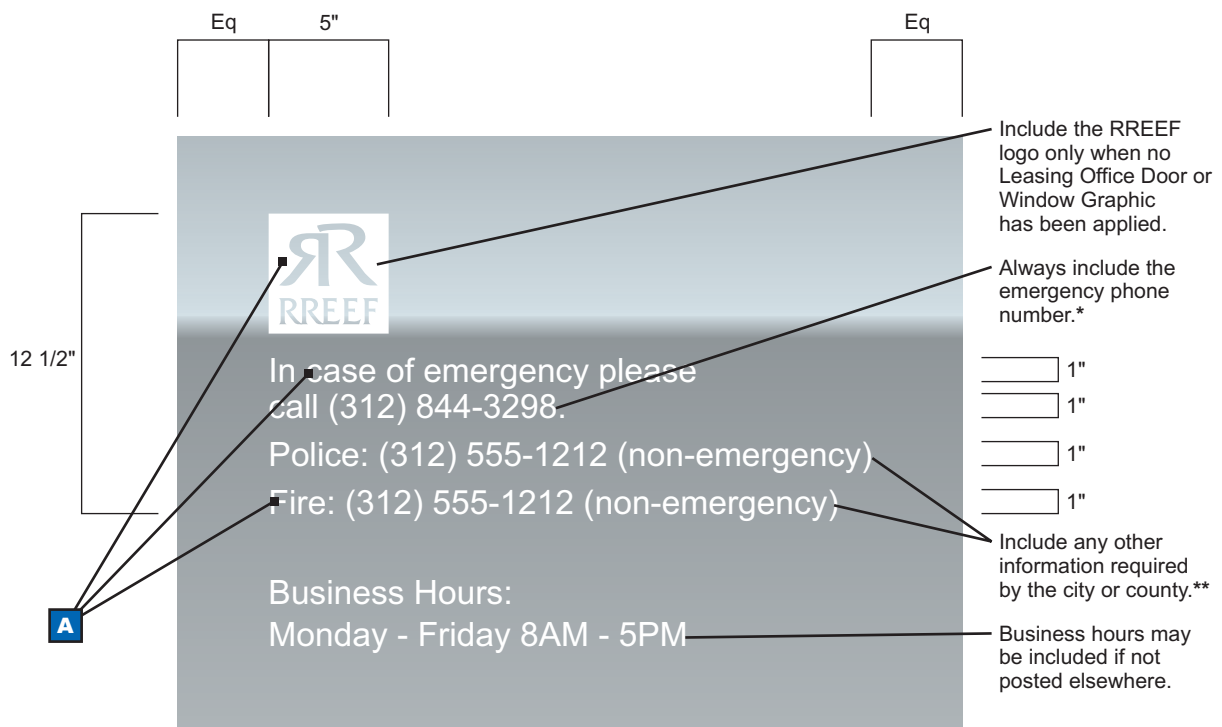

Emergency Information with RREEF Logo

*Can be a Patrol Service, Answering Service or however an employee can be reached after hours.

**All Police or Fire numbers listed must have the words "(non-emergency)" added for liability reasons.

Specifications:

A #220-10 3M high performance white vinyl film or as required by the property sign criteria.*

* Always apply on the inner surface of glass unless it is tinted.

E4.1

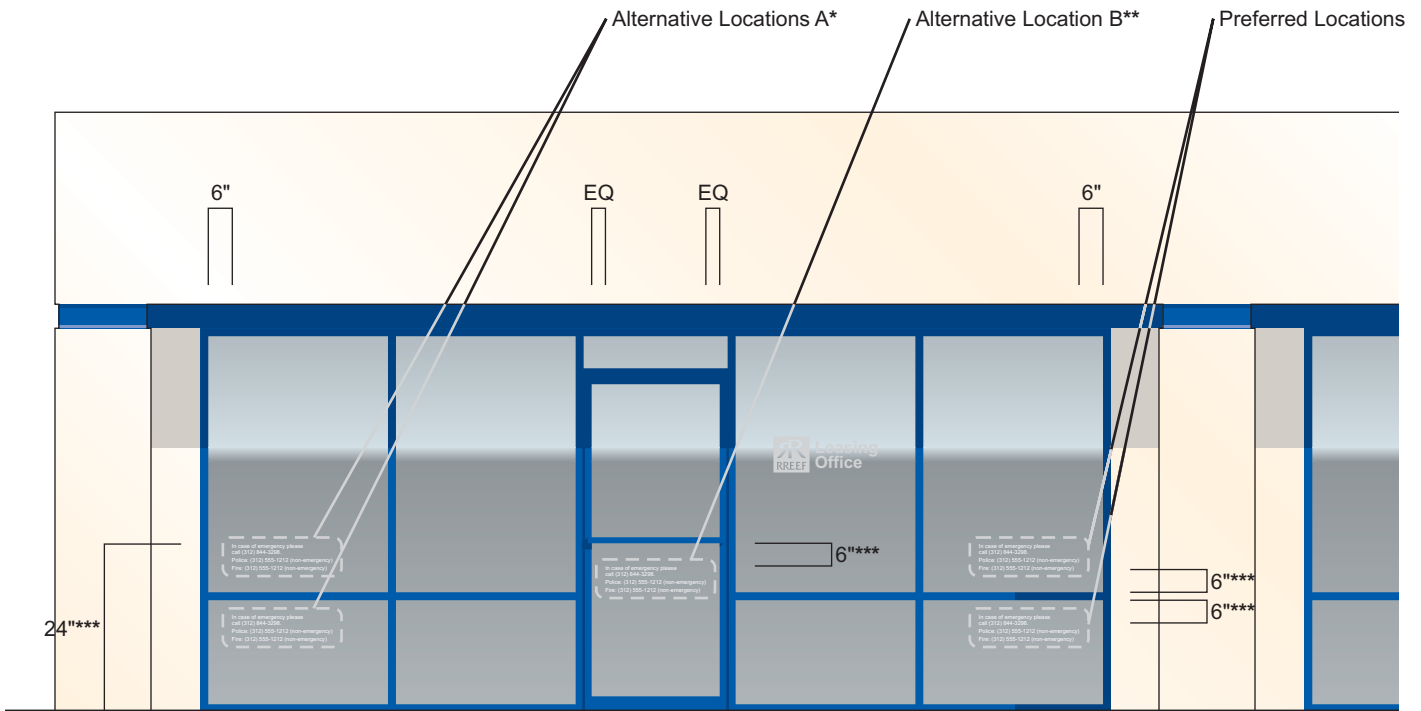

Typical On-Site Leasing Office Entrance

*Use only when no right side window exists.

**Use only when no right or left side window exists.

***Use the 6" measurement when there is a horizontal window frame or door pull. Otherwise, place the sign a maximum of 24" from the floor.



Leasing Office Impact Wall Graphic

General Requirements:

These are to be used on the wall located behind the receptionist or in an entrance lobby of Property Management offices only.

The 24" option is preferred. The 18" version is allowed where obstructions such as counters, reception desks, chairs or tables are in place (See E5.2).

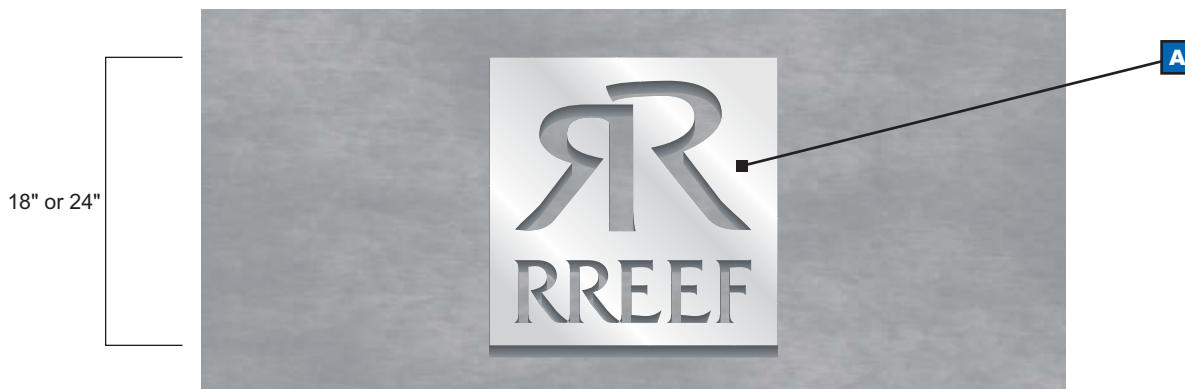

RREEF Impact Wall Graphic

Specifications:

- A** 1/2" deep fabricated Satin Stainless Steel letters with horizontal brushed finish, stud mounted through the wall with the back flush to the wall surface.

E5.1

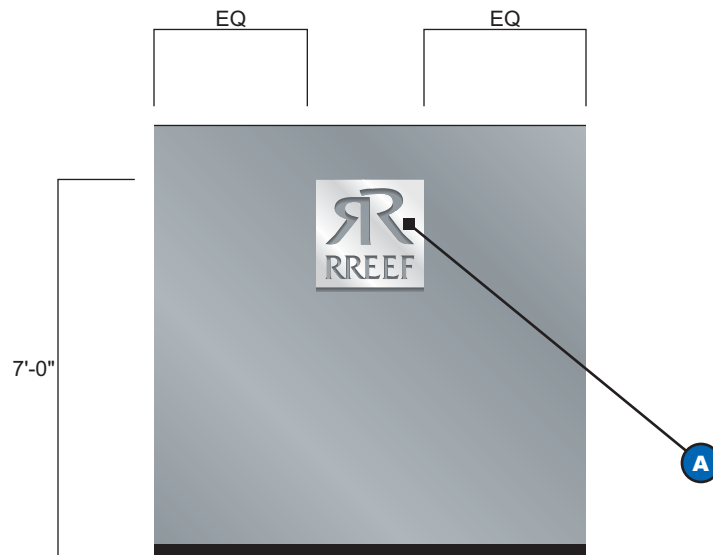

Option A (Walls without obstructions)

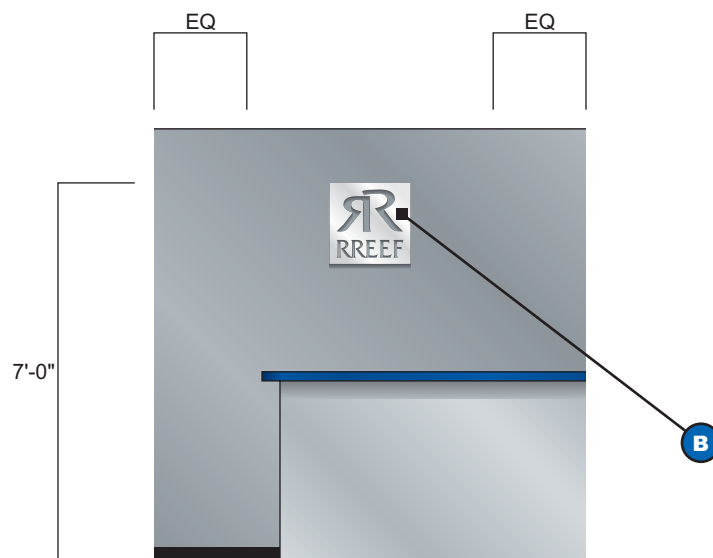

Option B (Walls with Obstructions)

Sign Types:

- A** 24" Impact Wall Graphic.
- B** 18" Impact Wall Graphic.

Photo to be added later.

RREEF Impact Wall Graphic Photo

General Requirements:

This sign should be used for properties where RREEF has an on-site management office.

The design of the Building Directory may be customized according to the building architecture and colors.

The contact information must be placed in the lower right hand corner as indicated below, and laid out according to the Typical Building Directory Contact Information Layout on page E6.2.

Building directories must graphically indicate both the location of the observer ("You are here") and the location of the leasing office.

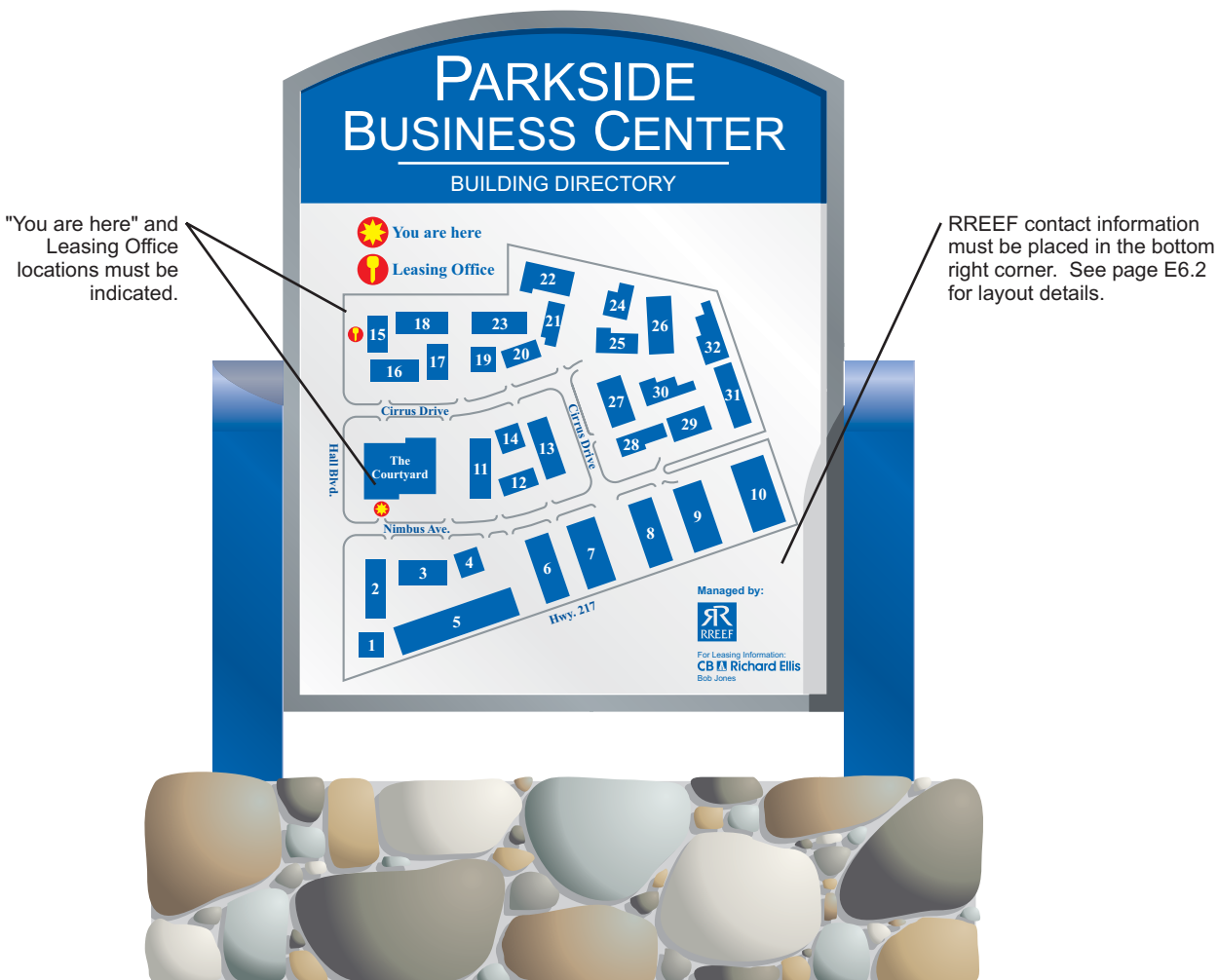

Typical Building Directory

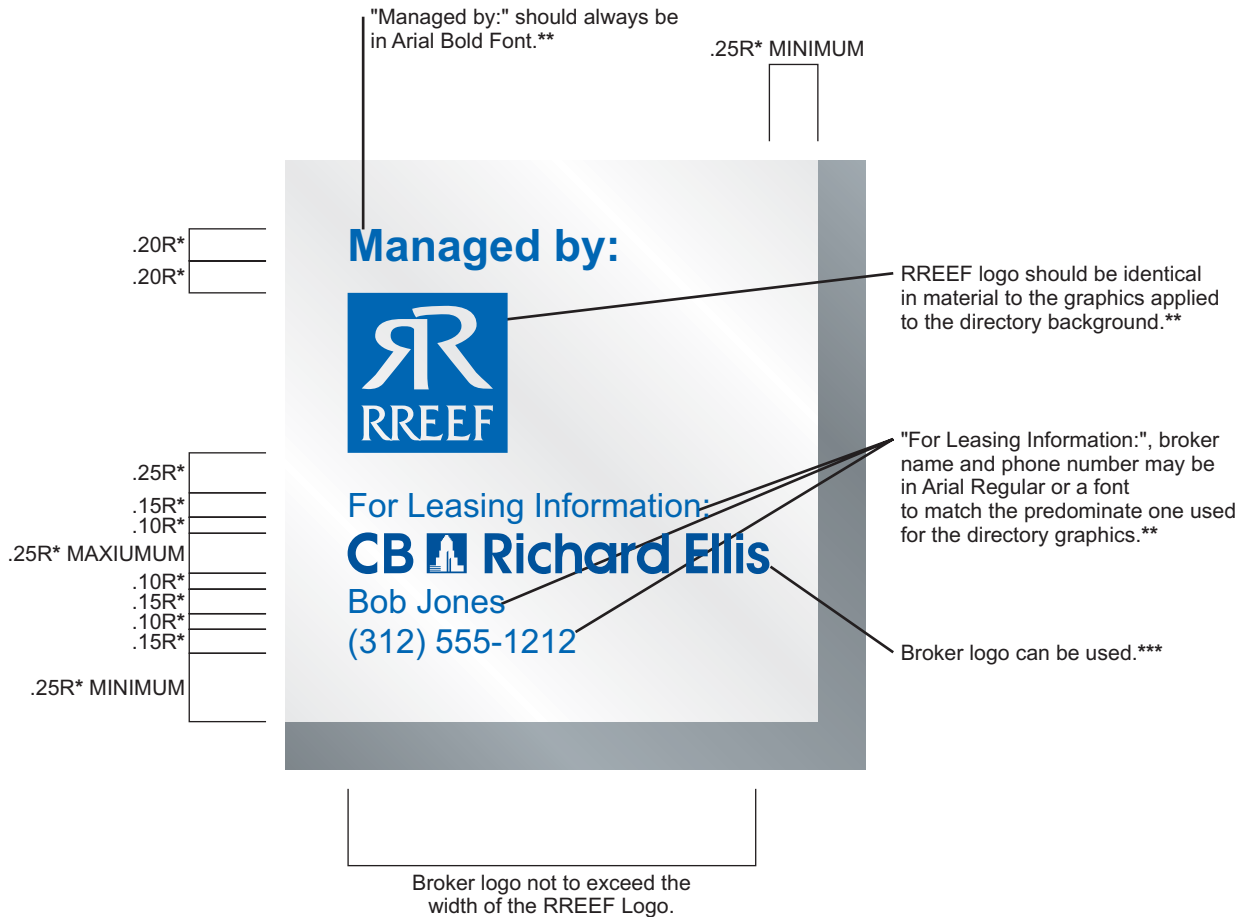

Typical Building Directory Contact Information Layout

* "R" is a distance equal to the height of the RREEF logo.

** All contact information must be in white, black or PMS 287 blue, whichever contrasts best with the directory background.

***Broker's logo's colors can be either in accordance with the park's signage criteria, or their own if not in violation of the park's criteria.

General Requirements:

Flags are recommended as an outstanding way to draw attention to the leasing office.

Screened nylon flags should be purchased in bulk as cost on an individual basis is very high. An alternative in case of a single unit purchase is to use vinyl banner material with premium applied vinyl.

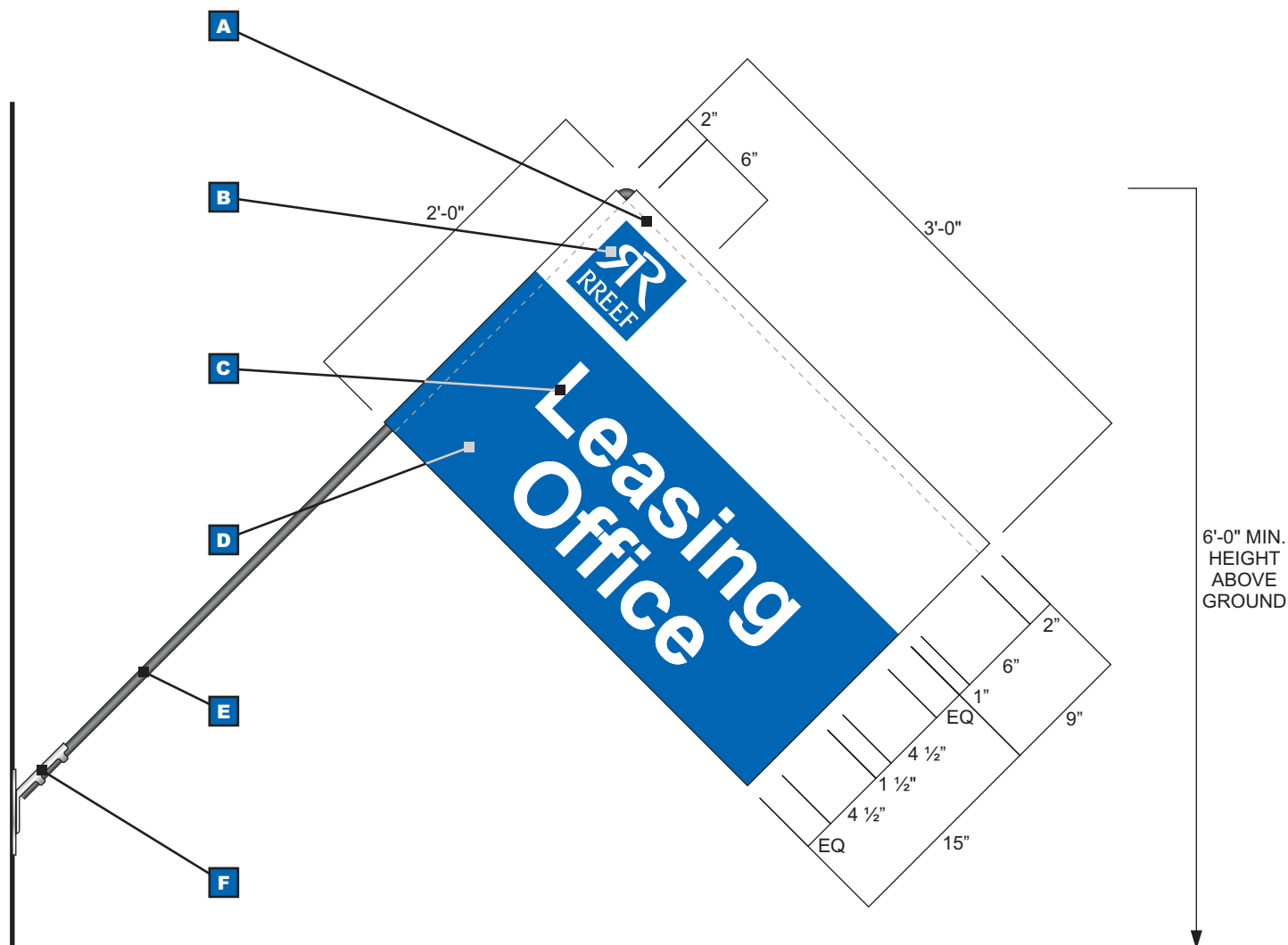

Typical Leasing Office Flag

Specifications:

- A** White nylon with sewn-in pole pockets at top and side.
- B** PMS 287 Blue silk-screened copy and graphics.
- C** White silk-screened copy and graphics.
- D** Dark blue nylon to match PMS 287 Blue with sewn-in pole pocket at the side.
- E** Black 3/4" x 5'-0" x 3'-0" aluminum flag pole with a 90° bend.
- F** Natural finish anodized aluminum 45° flag bracket.

Photo to be added later.

Typical Leasing Office Flag Photo